



EasyTouch® and IntelliTouch® Pool and Spa Control System (with optional IntelliChlor® Salt Chlorine Generator) Load Center Installation Guide



IMPORTANT SAFETY INSTRUCTIONS
READ AND FOLLOW ALL INSTRUCTIONS
SAVE THESE INSTRUCTIONS

Technical Support

Contact Technical Support at:

Sanford, North Carolina (8 A.M. to 5 P.M.)

Phone: (800) 831-7133

Fax: (919) 566-8920

Moorpark, California (8 A.M. to 5 P.M.)

Phone: (800) 831-7133 (Ext. 6312)

Fax: (805) 553-5515

Web sites

visit www.pentairpool.com and staritepool.com

© 2011 Pentair Water Pool and Spa, Inc. All rights reserved.

1620 Hawkins Ave., Sanford, NC 27330 • (919) 566-8000

10951 West Los Angeles Ave., Moorpark, CA 93021 • (800) 553-5000

EasyTouch®, IntelliTouch®, IntelliChlor®, IntelliChem®, QuickTouch®, MobileTouch®, IntelliChem™, SpaCommand™, ScreenLogic2™ and Pentair Water Pool and Spa® is a trademark and/or registered trademark of Pentair Water Pool and Spa, Inc. and/or its affiliated companies in the United States and/or other countries. Jandy® is a registered trademark of Zodiac Pool Systems Inc.. Hayward® is a registered trademark of Hayward Industries Inc.. iPhone™ and iPad® is a trademark and/or registered trademark of Apple Corporation. Unless noted, names and brands of others that may be used in this document are not used to indicate an affiliation or endorsement between the proprietors of these names and brands and Pentair Water Pool and Spa, Inc. Those names and brands may be the trademarks or registered trademarks of those parties or others.

P/N 521139 Rev. A 04/20/11

Contents

IMPORTANT WARNING AND SAFETY INSTRUCTIONS	iii
General Installation Information	v
Section 1: Pentair Water Pool and Spa Control System Load Center and Power Center Overview	1
Load Center and Power Center Installation Overview	2
Load Center with subpanel (EasyTouch and IntelliTouch Systems)	3
Power Center (without built-in Subpanel) - IntelliTouch System Only	4
Preparing the Load Center and Power Center Enclosure	5
Mounting the Load Center and Power Center	6
Connecting AC Power to the Load Center and Power Center	7
Electrical Wiring High Voltage Connections	8
Installing Conduit and Wire to the Enclosure	8
Accessing the EasyTouch or IntelliTouch Circuit Board and Electronics	10
Connecting the EasyTouch System Relays	11
Connecting the IntelliTouch System Relays	12
Installing Valve Actuators	13
Adjusting the valve position	13
Installing and Connecting Temperature Sensors	15
Water Temperature Sensor	15
Ambient Air Temperature Sensor (for freeze protection)	15
Solar Temperature Sensor (Optional)	16
Connecting a Standard Gas Heater (EasyTouch and IntelliTouch System)	17
Wiring Pentair UltraTemp Heat Pump	18
Wiring Pentair IntelliFlo Pumps	18
Connecting IntelliChlor (SCG) Power Cord to the Enclosure	20
Connecting IntelliChlor (SCG) COM Port Cable	21
Wiring a Salt Chlorine Generator	23
Wiring IntelliChlor	23
Wiring IntelliChlor (SCG) Transformer to a Filter Pump	24
Rewiring the IntelliChlor SCG Transformer for 120VAC	26
Rewiring the System Transformer for 240 VAC	27
Section 2: EasyTouch System Overview	28
EasyTouch 8 and 4 Pool and Spa Control System Kit Contents	28
EasyTouch Accessory Equipment	28
EasyTouch Model Part Numbers	29
EasyTouch System Start-Up	30
EasyTouch Circuit Board Connections	31
EasyTouch System Wiring Diagram	32

Contents (continued)

Section 3: IntelliTouch System Overview	33
IntelliTouch System Components	33
Load Center or Power Center	33
IntelliTouch Personality Kits	33
IntelliTouch Accessory Power Center Expansion Kits	34
IntelliTouch Personality Kit Contents	34
Optional Equipment (IntelliChem)	34
Optional IntelliTouch Expansion Enclosure	36
Kit Contents	36
Affixing the System Wiring Diagram Label	36
System Start-Up	37
Check Electronics	37
System Test	37
Testing the auxiliary relays	37
Solar System Installation	38
Solar System Start-Up	38
Pool Cleaner Protection	38
Installing the IntelliTouch Control Panel	39
IntelliTouch Outdoor Control Panels	40
IntelliTouch System Wiring Diagrams	41
Plumbing Requirements	44
Equipment Location	45
Glossary	47

IMPORTANT WARNING AND SAFETY INSTRUCTIONS

Read and Follow all WARNING and SAFETY Instructions

⚠ DANGER SERIOUS BODILY INJURY OR DEATH CAN RESULT IF THIS PRODUCT (UNIT) IS NOT INSTALLED AND USED CORRECTLY.

⚠ DANGER INSTALLERS, POOL OPERATORS AND POOL OWNERS MUST READ THESE WARNINGS AND ALL INSTRUCTIONS BEFORE USING THIS PRODUCT. This Guide provides installation and operation instructions for the product. Consult Pentair Water Pool and Spa, Inc. (“Pentair”) with any questions regarding this product.

⚠ WARNING This product is intended for use in swimming pool applications only.

⚠ WARNING Most states and local codes regulate the construction, installation, and operation of public pools and spas, and the construction of residential pools and spas. It is important to comply with these codes, many of which directly regulate the installation and use of this product. Consult your local building and health codes for more information.



IMPORTANT NOTICE - Attention Installer: This Installation Guide (“Guide”) contains important information about the installation, operation and safe use of this product. This Guide should be given to the owner and/or operator of this equipment.

Attention User: This Guide contains important information that will help you in operating and maintaining this product. Please retain it for future reference.

⚠ WARNING Before installing this product, read and follow all safety warning notices and instructions which are included. Failure to follow safety warnings and instructions can result in severe injury, death, or property damage. Call (800) 831-7133 for additional free copies of these instructions.

This product is designed and manufactured for safe and reliable service when installed, operated and maintained according to the information and installation codes referred to in this Guide.

⚠ This is a safety alert symbol. When you see this symbol in this manual or on the product, look for one of the following signal words; **DANGER**, **WARNING**, **CAUTION** and **NOTICE** and comply with the information. Be alert to the potential hazard. Ensure to read and comply with all of the warnings and cautions in this manual.

Risk of Electrical Shock or Electrocution!

- Always disconnect power at the circuit breaker before servicing the load center
- Improper installation can create an electrical shock hazard that can result in death or serious injury.

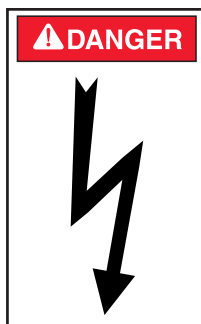

This product must be installed by a licensed or certified electrician or a qualified pool professional in accordance with the National Electrical Code (NEC), NFPA 70 or the Canadian Electrical Code (CEC), CSA C22.1. All applicable local installation codes and ordinances must also be adhered to. Improper installation will create an electrical hazard which could result in death or serious injury to pool users, installers or others due to electrical shock, and may also cause damage to property. Always disconnect the power to the pool light at the circuit breaker before servicing the light. Failure to do so could result in death or serious injury to serviceman, pool users or others due to electrical shock.

IMPORTANT WARNING AND SAFETY INSTRUCTIONS

⚠ DANGER



Water temperature in excess of 100° F (37.7° C) may be hazardous to your health. Prolonged immersion in hot water may induce hyperthermia. Hyperthermia occurs when the internal temperature of the body reaches a level several degrees above normal body temperature of 98.6° F (37° C.). Effects of hyperthermia include: (1) Unawareness of impending danger. (2) Failure to perceive heat. (3) Failure to recognize the need to leave the spa. (4) Physical inability to exit the spa. (5) Fetal damage in pregnant women. (6) Unconsciousness resulting in danger of drowning. The use of alcohol, drugs, or medication can greatly increase the risk of fatal hyperthermia in hot tubs and spas.

⚠ WARNING

A pool or spa pump must be installed by a qualified pool and spa service professional in accordance with the National Electrical Code and all applicable local codes and ordinances. Improper installation may create an electrical hazard which could result in death or serious injury to pool users, installers, or others due to electrical shock, and may also cause damage to property.

⚠ WARNING

The use of alcohol, drugs, or medication can greatly increase the risk of fatal hyperthermia in hot tubs and spas. This product is intended to control heaters with built-in high limit circuits **ONLY**. Failure to do so may cause property damage or personal injury.

⚠ WARNING

Do not use this product to control an automatic pool cover. Swimmers may become entrapped underneath the cover.

⚠ WARNING

For units intended for use in other than single-family dwellings, a clearly labeled emergency switch shall be provided as part of the installation. The switch shall be readily accessible to the occupants and shall be installed at least five (5) feet (1.52 m) away, adjacent to, and within sight of, the unit.

⚠ WARNING

Except for listed spa-side remote controls, install a minimum of five (5) feet (1.52 m) from the inside wall of the pool and spa.

⚠ WARNING

The electrical supply for this product must include a suitably rated switch or circuit breaker to open all ungrounded supply conductors to comply with the National Electrical Code (NEC), NFPA 70 or the Canadian Electrical Code (CEC), CSA C22.1. All applicable local installation codes and ordinances must also be adhered to. The disconnecting means must be readily accessible to the tub occupant but installed at least five 5ft. (1.52 m), (Canada 3 m (9.75 ft) from the inside wall of the pool.

⚠ WARNING

Use only copper supply conductor's rated for 60C/75C sized based on ampacity to support all loads (refer to NEC tables). Load center input supply to be protected by 150 Amp Maximum, 240 VAC Main Circuit Breaker.

For information about the Virginia Graeme Baker Pool and Spa Safety Act, contact the Consumer Product Safety Commission at (301) 504-7908 or visit www.cpsc.gov.

NOTE: Always turn off all power to the pool pump before installing the cover or working on any suction outlet.

Two Speed Pump Controls Notice (Title 20 Compliance)

Please read the following important Safety Instructions - When using two-speed pumps manufactured on or after January 1, 2008, the pump's default circulation speed **MUST** be set to the **LOWEST SPEED**, with a high speed override capability being for a temporary period not to exceed one normal cycle, or two hours, whichever is less.

IMPORTANT WARNING AND SAFETY INSTRUCTIONS

FCC Standard - 47 CFR Part 15, Subpart C (Section 15.247). This version is limited to chapter 1 to chapter 11 by specified firmware controlled in the U.S.A.

Canada - Industry Canada (IC) - The IntelliChlor device complies with RSS210 of Industry Canada. (1999). Operation is subject to the following two conditions: (1) this device may not cause interference, and (2) this device must accept any interference, including interference that may cause undesired operation of the device.

Instruction to user - The IntelliChlor device has been tested and found to comply with the limits for a Class B digital device, pursuant to Part 15 of the FCC Rules. These limits are designed to provide reasonable protection against harmful interference in a residential installation. The IntelliChlor device generates, uses and can radiate radio frequency energy and, if not installed and used in accordance with the instructions, may cause harmful interference to radio communications. However, there is no guarantee that interference will not occur in a particular installation. If this device does cause harmful interference to radio or television reception, which can be determined by switching the device off and on, the user is encouraged to try to correct the interference by one or more of the following measures:

- Reorient or relocate the receiving antenna.
- Increase the separation between the equipment and receiver.
- Connect the equipment into an outlet on a circuit different from that to which the receiver is connected.
- Consult the dealer or an experienced radio/TV technician for help.

Note: The user is cautioned that changes and modifications made to the IntelliChlor device without the approval of the manufacturer could void the user's authority to operate this equipment.

General Installation Information

1. All work must be performed by a licensed electrician, and must conform to all national, state, and local codes.
2. Install to provide drainage of compartment for electrical components.
3. If this system is used to control underwater lighting fixtures, a ground-fault interrupter (GFCI) must be provided for these fixtures. Conductors on the load side of the ground-fault circuit-interrupter shall **not** occupy conduit, junction boxes or enclosures containing other conductors unless such conductors are also protected by a ground-fault circuit-interrupter. Refer to local codes for details.
4. A terminal bar stamped  is located inside the supply terminal box. To reduce the risk of electric shock, this terminal must be connected to the grounding means provided in the electric supply service panel with a continuous copper wire equivalent in size to the circuit conductors supplying this equipment (no smaller than 12 AWG or 3.3 mm). The bonding lug(s) provided on this unit are intended to connect a minimum of one No. 8 AWG for US installation and two No. 6 AWG for Canadian installations solid copper conductor between this unit and any metal equipment, metal enclosures or electrical equipment, metal water pipe, or conduit within 5 feet (1.5 m) of the unit.
5. The electrical supply for this product must include a suitably rated switch or circuit breaker to open all ungrounded supply conductors to comply with in accordance with the National Electrical Code (NEC), NFPA 70 or the Canadian Electrical Code (CEC), CSA C22.1. All applicable local installation codes and ordinances must also be adhered to. The disconnecting means must be readily accessible to the tub occupant but installed at least 10 ft. (3.05 m) from the inside wall of the pool.
6. **GAS HEATER:** This automation control system is designed to supply high voltage (120 VAC / 240 VAC) to a gas heater and override the thermostat in the heater's control circuit. This automation control system is intended to control gas heaters with a high temperature limit switch(s) safety circuit.

Pentair Water Pool and Spa®
IMPORTANT SAFETY INSTRUCTIONS
For Installation of Electrical Controls at Equipment Pad
(ON/OFF Switches, Timers and Automation Load Center)

⚠ CAUTION

Install all electrical controls at equipment pad, such as on/off switches, timers, and control systems, etc. to allow the operation (start-up, shut-down, or servicing) of any pump or filter so the user does not place any portion of his/her body over or near the pump strainer lid, filter lid or valve closures. This installation should allow the user enough space to stand clear of the filter and pump during system start-up, shut down or servicing of the system filter.

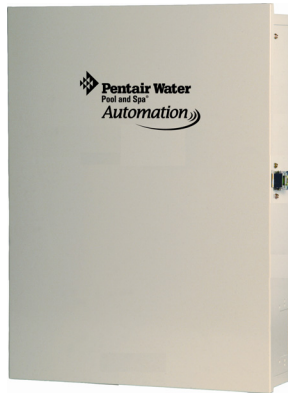

CAUTION! INSTALL LOAD CENTER AND POWER CENTER TO ALLOW USER ENOUGH SPACE TO STAND CLEAR OF PUMP AND FILTER WHEN SERVICING.

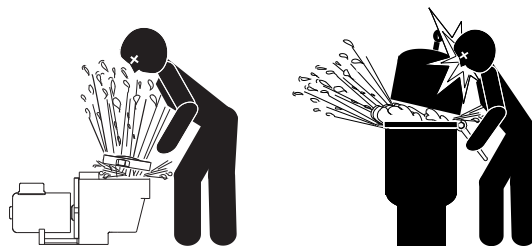

HAZARDOUS PRESSURE: STAND CLEAR OF PUMP AND FILTER DURING START-UP

Section 1

Pentair Water Pool and Spa® Control Load Center and Power Center Overview

Load Center and Power Center Description

Load Center with sub-panel (EasyTouch® and IntelliTouch®): A Load Center enclosure provides a built-in a 120 VAC/240 VAC 150 AMP circuit breaker base (sub-panel) for high-voltage power relays, transformer, and low voltage circuit breakers. A Load Center can be factory configured for an EasyTouch (8 or 4 auxiliary relays) or IntelliTouch (for Personality Interface Kits, see page 33) automation control system. The optional IntelliChlor salt chlorine generator (SCG) transformer is available in the Load Center enclosure. The Load Center dimensions are 26" H x 17" W x 5¼" D.



EasyTouch/IntelliTouch Load Center

Note. For EasyTouch and IntelliTouch product information, see the Pentair Product Catalog.

Power Center without sub-panel (IntelliTouch only): A Power Center enclosure does not include a built-in circuit breaker base (subpanel). An IntelliTouch automation control system Power Center is factory configured (depending on the IntelliTouch Personality interface kit. Multiple Power Centers can be connected together for additional high voltage relay and transformer requirements. The optional IntelliChlor Salt Chlorine Generator (SCG) transformer is available in the Power Center enclosure. The Power Center dimensions are 20" H x 17" W x 5¼" D.

Note: For IntelliTouch systems (see page 33), up to three additional Power Centers (with Expansion Center Personality kit, i5x or i10x) can be connected to a base IntelliTouch Load Center or Power Center (models i5+3, i5+3S, i7+3, i9+3, i9+3S, i10+3D). For more information about using multiple expansion centers, refer to the IntelliTouch Systems User's Guide (P/N 521075).

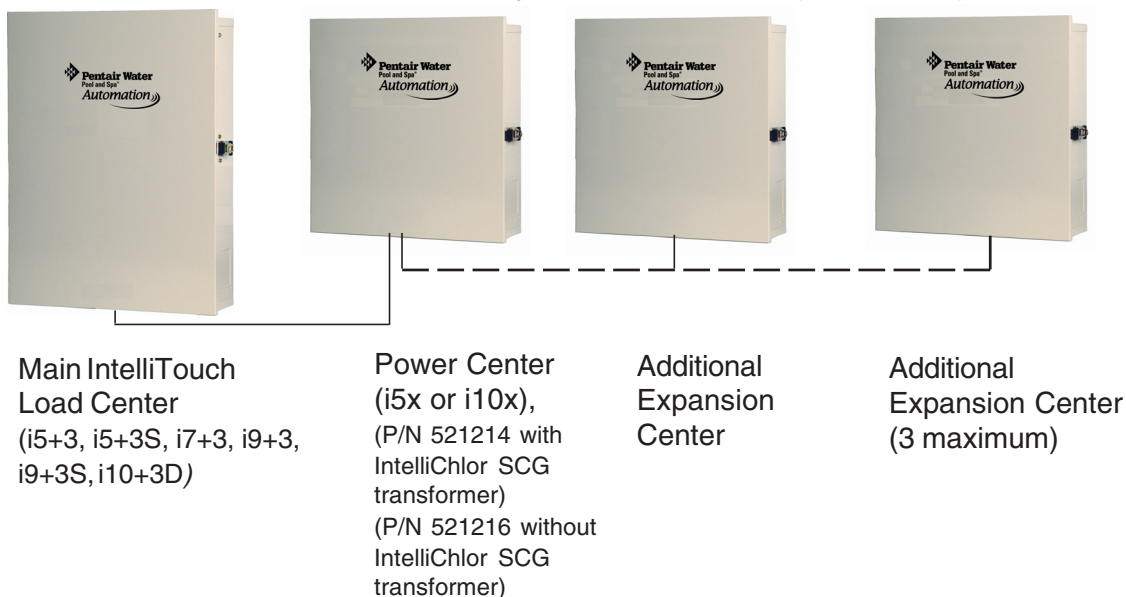

Load Center and Power Center Installation Overview



RISK OF ELECTRICAL SHOCK. BEFORE REMOVING THE HIGH VOLTAGE COVER PANEL FROM THE ENCLOSURE switch the main power **OFF** into the home at the main circuit breaker box.

Before installing the Load Center or Power Center read the following guidelines carefully:

- The Load Center and Power Center must be installed at the equipment pad.
- AC power for the Load Center or Power Center must be provided from the main circuit breaker panel located at the house.
- All electrical equipment, except for UL Listed spa-side remote switches, must be installed no less than five (5) feet (1.5 m), (Canada, 3 m (9.75 ft) from pool and/or spa, and comply with all national, state, and local codes (UL Listed spa-side remote switches may be installed at near waterline).
- Install the Load Center or Power Center no less than five (5) feet (1.5 m) from pool, spa, hot tub, pumps, heater, valves, and sensors.
- The TYPE 3R “Rainproof” enclosure can be mounted outside or inside of a pool equipment shed or other enclosure.
- Before choosing the final location for the enclosure, consider the length of all of the conductors that will have to be connected to the enclosure. Make sure to consider cable lengths for the sensors to the load center location. The air temperature sensor cable is three (3) feet (91.44 cm) long and the water temperature sensor cable is 25 feet (7.62 m) long.
- Mount the load center on a flat vertical surface so the conduit knockouts are located at the bottom of the enclosure. Upper and lower brackets are provided to mount the enclosure.
- **DO NOT** mount the enclosure horizontally. Water can enter the conduit knockouts and cause damage to the system and an electrical shock hazard. Install with conduit knockouts down.
- Consider the load center location when routing conduit carrying the AC power to the load center, and the conduit that will be run to the high voltage equipment.
- Install the load center so that drainage is provided for all electrical components.
- Motors should be listed for pool and spa applications and have built-in thermal protection.
- Allow at least 5 ft (1.5 m) of unobstructed access to the front of the load center for the owner or service personnel.
- The load center provides grounding screw terminals for grounding all equipment. All equipment including the load center enclosure must be bonded to earth ground.

Load Center (with built-in Subpanel) - EasyTouch and IntelliTouch Systems

The Load Center must be installed at the equipment pad. The AC power for the Load Center is provided from the main-panel circuit breaker located at the house.

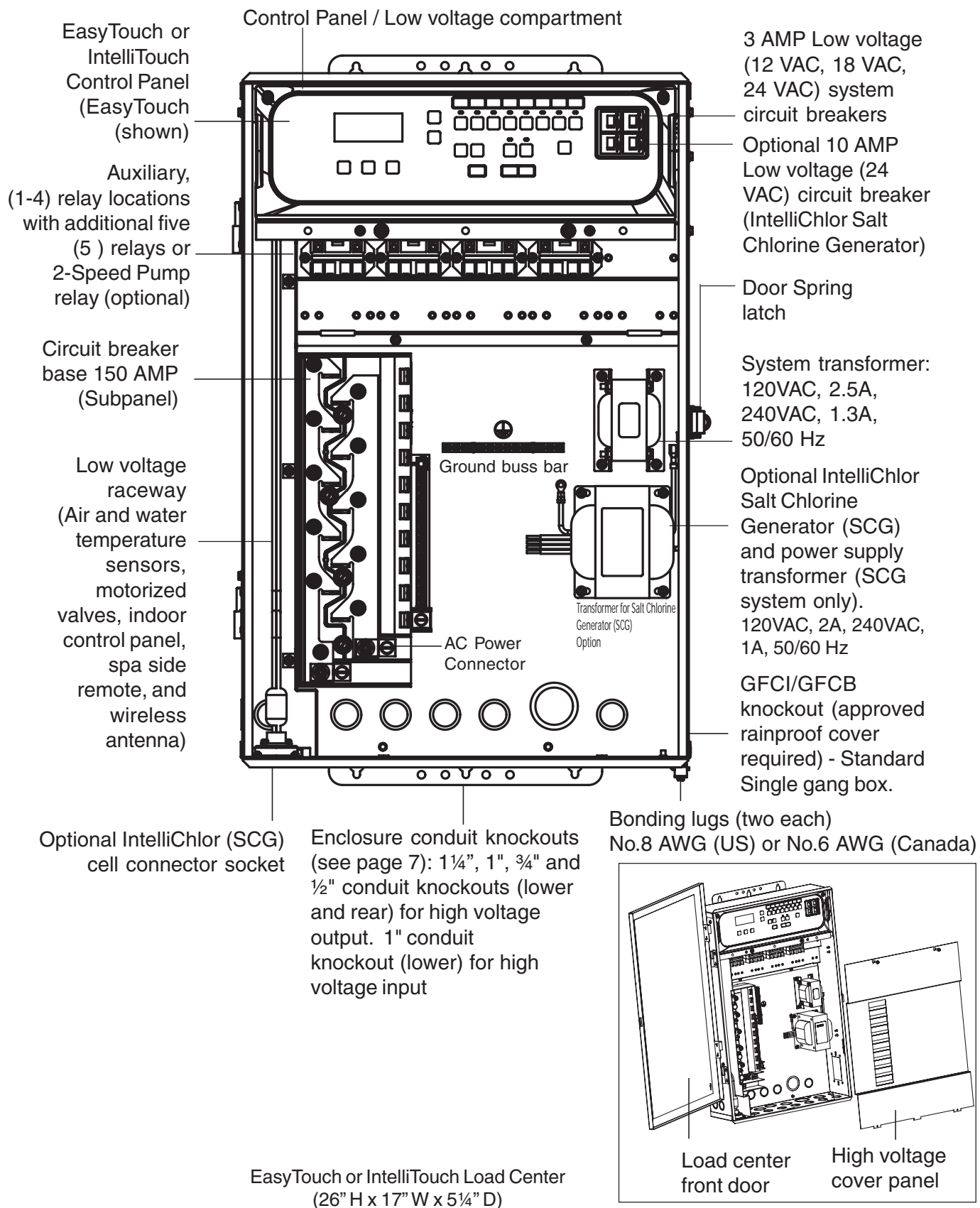

Power Center (without built-in Subpanel) - IntelliTouch System Only

The IntelliTouch Power Center (without sub-panel) must be installed at the equipment pad. AC power to the Power Center is provided from the an electrical circuit breaker panel (sub-panel) installed at the equipment pad. The Power Center should be installed next to the sub-panel.

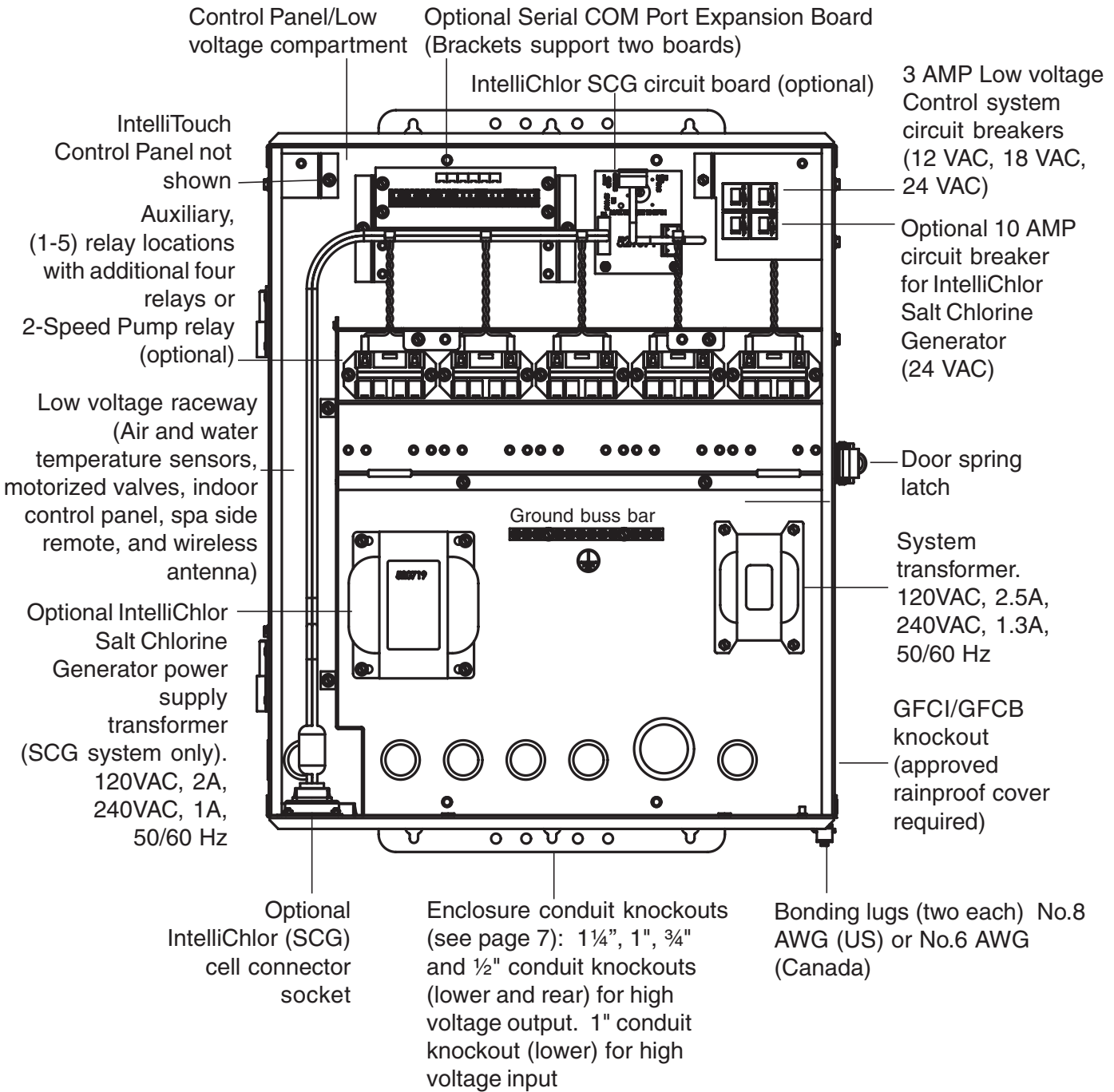

IntelliTouch Power Center (20" H x 17" W x 5¼" D)
(Front view with door and high voltage cover panel removed)

Preparing the Load Center and Power Center Enclosure

WARNING BEFORE INSTALLING THE LOAD CENTER AND POWER CENTER, ALWAYS SWITCH OFF THE MAIN POWER into the home at the main circuit breaker box.

Before mounting the Load Center or Power Center, first remove the front door and the high voltage cover panel to access the enclosure conduit knockouts and low voltage raceway (see pages 3 and 4).

To remove the Load Center or Power Center high voltage cover panel:

1. Unpack the Load Center or Power Center from the shipping carton.
2. Unlatch the front door spring latch and open the front door.
3. Remove the two (2) retaining screws securing the high voltage cover-panel. Remove the HIGH VOLTAGE COVER PANEL from the enclosure.
4. For new installation, proceed with:
 - **Mounting the Load Center and Power Center**, page 6
 - **Connecting AC Power to the Load Center and Power Center**, page 7
 - **Electrical Wiring and High Voltage Connections**, page 8
 - **Installing Conduit and Conductors to the Enclosure**, page 8
 - **Accessing the EasyTouch or IntelliTouch Control Circuit Board and Electronics**, page 10
 - **Connecting a Standard Gas Heater (EasyTouch and IntelliTouch System)**, page 17
5. After electrical connections have been completed, reinstall the high voltage panel and secure it with the two (2) retaining screws.

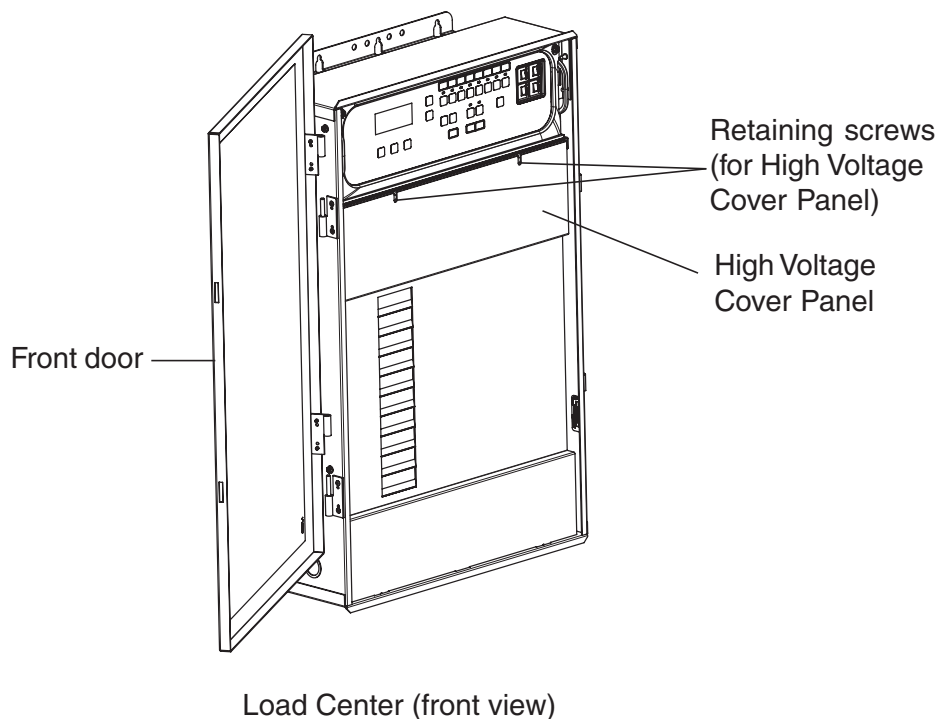

Mounting the Load Center and Power Center

Mount the Load Center (EasyTouch enclosure show below) and Power Center on a flat vertical surface, such as a wall or post at eye level, at least 5 ft. (1.5 m), (Canada 3 m (9.75 ft)) from the pool, spa or hot tub.

To mount the Load Center and Power Center:

1. Position the enclosure against a vertical flat surface. If wall anchors are being used, support the enclosure in position (horizontally level and square) against the surface and mark the bracket hole pattern on the wall.
2. Secure the enclosure with three (3) screws in the top and lower mounting bracket holes. If using wall anchors, drill and set the anchors and secure the enclosure with screws.

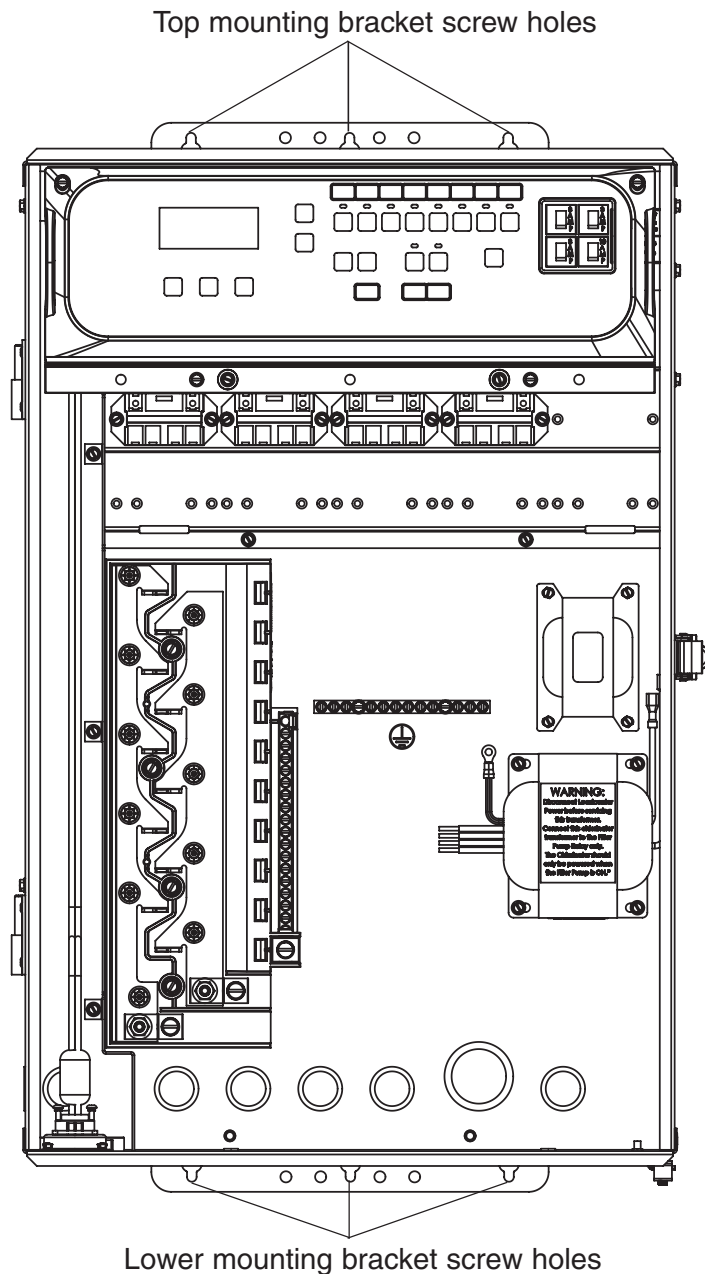

Load Center (front view)
(front door and high voltage panel removed)

Connecting AC Power to the Load Center and Power Center

Before installing electrical conduits and connecting AC power to the Load Center and Power Center enclosure, read the following recommended guidelines:

⚠ WARNING TO AVOID AN ELECTRICAL HAZARD AND EQUIPMENT DAMAGE TO THE ENCLOSURE AND INTELLICHLOR CELL: FIRST DISCONNECT AC POWER TO THE ENCLOSURE BEFORE CONNECTING THE INTELLICHLOR COMMUNICATION CABLE.

- Determine the number of low and high voltage circuits being used in the Load Center or Power Center. The conduit size and runs needed based on the conductor size, and the number of conductors within the conduit. The enclosure conduit knockouts sizes are 1¼", 1", ¾" and ½".
- Enclosure conduit knockouts for AC power are located on the sides, bottom and back of the enclosure. Conduit knockout sizes for AC power are: 1¼", 1", ½" and ¾". It is recommended to use 1¼" x 1" conduit for the main AC power conductors.
- The Load Center and Power Center enclosure must be located a minimum of 5 ft. (1.5 m), (Canada 3 m (9.75 ft)) from the inside wall of pool or spa.

Remove the enclosure conduit knockouts as needed:

- Low voltage raceway has two ½" x ¾" conduit knockouts located on the left side and rear of the enclosure.
- High voltage compartment has twelve ½" x ¾", five ¾" x 1" and two 1¼" x 1" conduit knockouts located on the bottom of the enclosure.

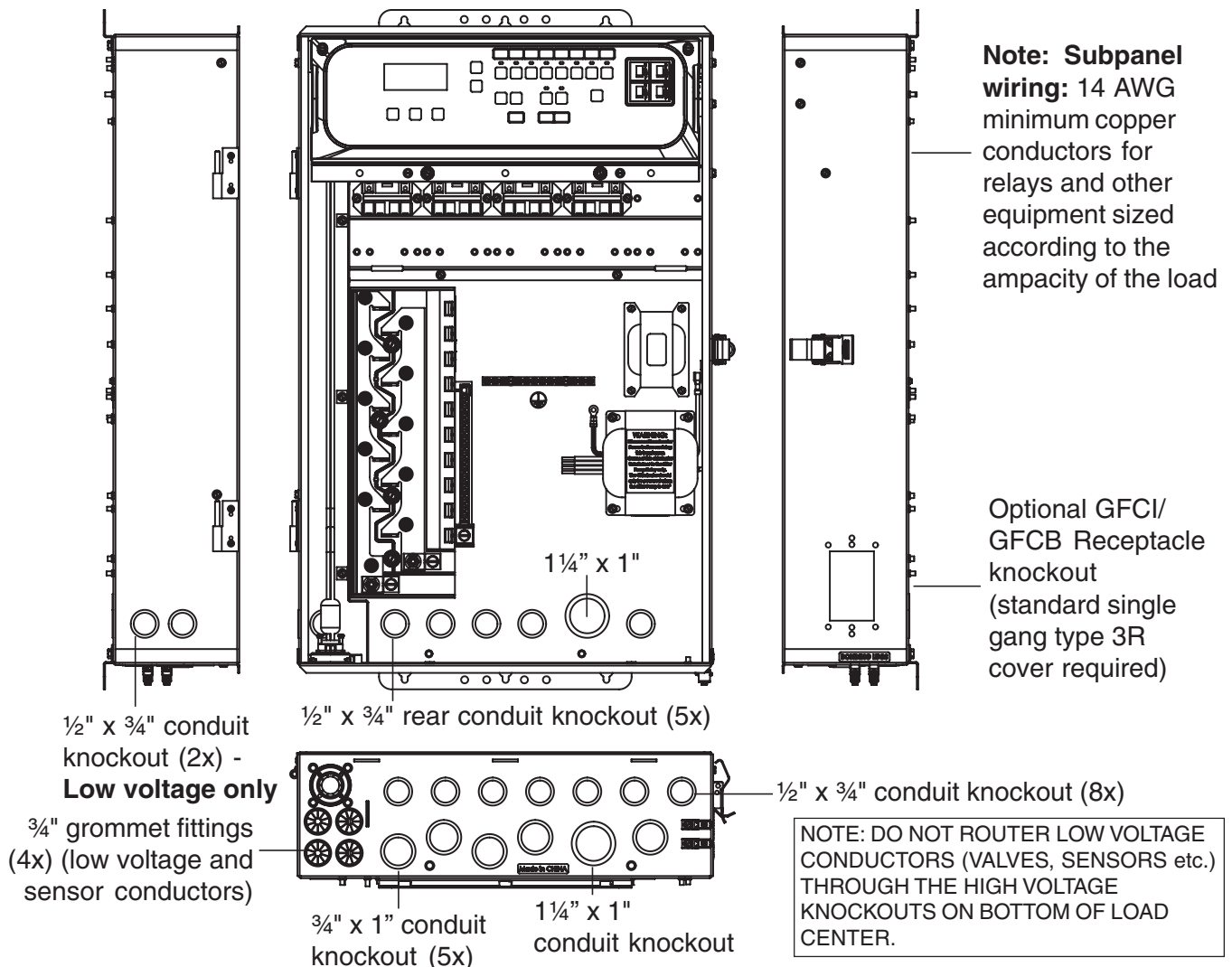

EasyTouch Load Center (lower, side and back panel knockouts)

Electrical Wiring and High Voltage Connections

Main AC Power Connection (EasyTouch and IntelliTouch Circuit Breaker Subpanel)

The EasyTouch and IntelliTouch Load Center with circuit breaker sub-panel is rated for 150 AMP maximum Single Phase (3 conductor). Run properly rated conductors (L1,L2, N, and GROUND) from the primary house electrical panel to the main AC power connections on the Load Center circuit breaker base (see page 27). The connection at the main house panel should be to a 240 VAC circuit breaker rated at 150 AMP maximum.

Grounding and Bonding Connections

Connect a ground conductor from the primary house electrical panel to the Load Center or Power Center GROUND BUS BAR (see page 27). Also ground each piece of high voltage (120 VAC or 240VAC) equipment that is connected to the Load Center or Power Center relays or circuit breakers. Also connect the Load Center and Power Center to the pool bonding system using 8 AWG (6 AWG for Canada) conductor. There are two (2) GROUND LUGS provides on the bottom of the Load Center and Power Center.

Circuit Breakers (For EasyTouch and IntelliTouch Load Center with sub panel)

Circuit Breakers are to be supplied and installed by the site installer. For recommended circuit breaker types, refer to the circuit breaker chart on the inside front door of the Load Center and Power Center. Be sure to follow all manufacturer's circuit breaker rating requirements. Some pool equipment require connection to ground fault circuit breakers (GFCI). Check local and NEC (CEC) codes for these requirements. **Note: For recommended field conductor gauge usage, refer to conductor size listed on the circuit breaker label.**

Installing Conduit and Conductors to the Enclosure

Before installing electrical conduit to the enclosure, read the following recommended guidelines:

NOTE: All electrical installation, including electrical wiring methods and materials used to complete the electrical installation of the EasyTouch and IntelliTouch Pool/Spa control system **MUST BE PERFORMED BY A SERVICE PROFESSIONAL AND/OR UNDER DIRECT SUPERVISION OF A QUALIFIED ELECTRICIAN** in accordance with the National Electrical Code or the Canadian Electric Code, as well as any local electrical codes in effect at the time of installation. **Refer to NEC 680 (b) or CEC 687-060, 062, and 066 for further details.**

- Determine the number of low and high voltage circuits being used in the EasyTouch and IntelliTouch Load Center and Power Center. The conduit size and runs is based on the conductor size, and the number of conductors within the conduit. *The number of pieces of equipment to be controlled will dictate the size of the conduit. DO NOT RUN HIGH VOLTAGE AND LOW VOLTAGE CONDUCTORS IN THE SAME CONDUIT.*
- Use 14 AWG minimum to 6 AWG maximum 140°/158° F (60°/70° C) or better copper conductors for relay circuits depending on the load requirement. Be sure to follow all NEC regulation safety codes for the number and size of conductors that can be installed in various sizes of conduit.
- Supply conductor must be sized to support all loads. The maximum supply current must NOT exceed 150 AMP at 120 VAC/240 VAC.
- Supply circuit must be protected by suitable breaker rated no higher than 150 AMP. If one relay is used for more than one device, verify that the total current draw (all equipment) does not exceed the current rating of the circuit.
- The EasyTouch and IntelliTouch automation control circuit board requires 120 VAC, 3A power to operate the control logic circuits and the optional IntelliChlor salt chlorine generator. This power should be connected to one of the circuit breakers in the sub-panel.

- To avoid obstruction into the Load Center and Power Center, when using electrical conduit complete the installation of the conduit before concrete is poured. Also, underground conduit should be positioned in well compacted soil. Ensure that all conduit joints are well sealed and watertight.

To install electrical conduit and conductors as needed

⚠ DANGER



TO AVOID AN ELECTRICAL HAZARD - Do not connect the power source conductors to the Load Center circuit breaker until all electrical connections for all loads (heaters, pumps, motorized valves, and lights etc.) have been completed.

- Use the rectangular knockout on the right side of the Load Center and Power Center enclosure to mount an approved GFCI or GFCB with rainproof type 3R cover (supplied by installer) for direct connection of underwater pool and spa lights.
- Use the one of the three low voltage raceway 3/4" holes located on the underside of the enclosure for the temperature sensor conductors (see page 7).

NOTICE: For the AC supply conductor into the Load Center and Power Center from the main circuit breaker at the house, use three conductors, one each for red, black, and white (or red, red and black for 240 VAC). The maximum load is 150 AMP at 120 VAC/240 VAC 60 Hz/50 Hz. These conductors should be secured to supply side of circuit breaker base. For the main AC power conduit, it is recommended to use the 1 1/4" x 1" conduit knockout located directly under the enclosure circuit breaker (see page 7).

EasyTouch Load Center Wiring Diagram

(for complete wiring details, see page 32 and inside front door of load center)

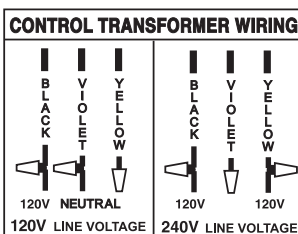
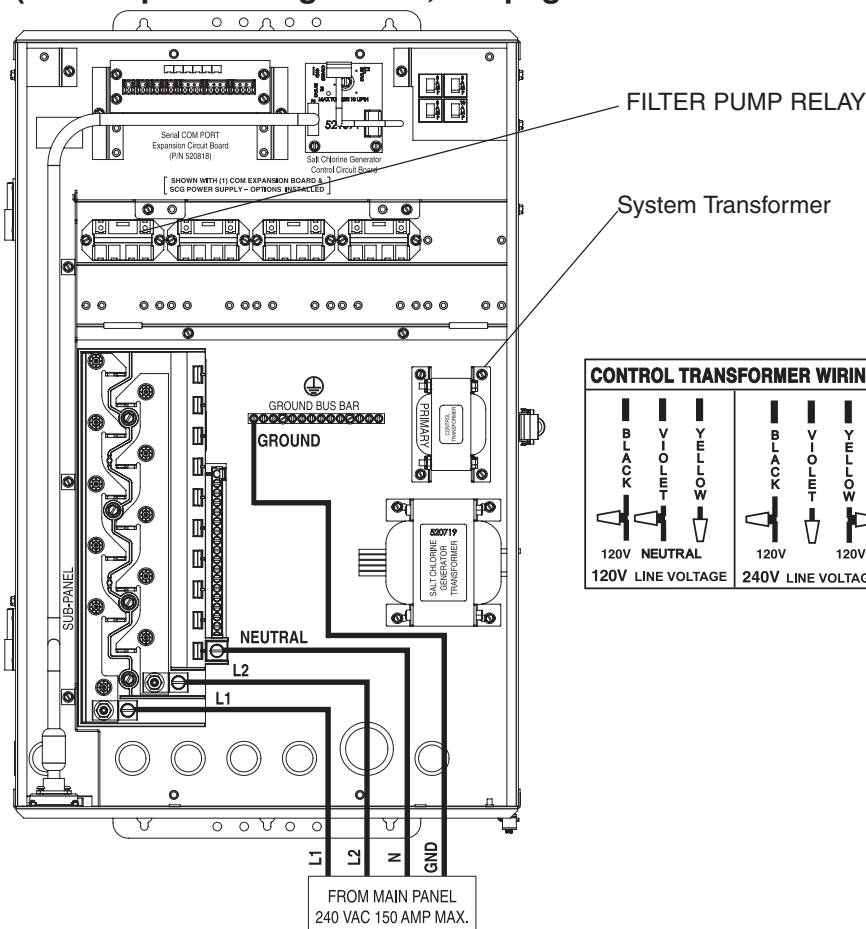

EasyTouch Load Center Wiring Instructions

- For Wiring IntelliChlor (SCG) Transformer to Filter Pump Relay, see page 24.
- For Rewiring the System Transformer for 240 VAC, see page 27.

Accessing the EasyTouch or IntelliTouch Control Circuit Board and Electronics

The main EasyTouch and IntelliTouch circuit board is located behind the control panel located on the front of the Load Center and Power Center. The main circuit board provides connectors for the auxiliary relays, valve actuators and sensors. To access the circuit board connectors, fold down the main control panel. Note: For IntelliTouch Personality circuit board models, see pages 40-42.

To access the control circuit board connectors:

1. Loosen the two retaining screws securing from the top edge of the control panel.
2. Fold down the control panel to access the rear of the circuit board for the electrical connections.
3. For relay, valve actuators and sensors installation and connection instructions see the following:
 - **Connecting EasyTouch System Relays**, page 11
 - **Connecting IntelliTouch System Relays**, page 12
 - **Installing Valve Actuators**, page 13
 - **Installing and Connecting Temperature Sensors**, page 15
4. After electrical connections have been completed, close the control panel and tighten the two retaining screws.

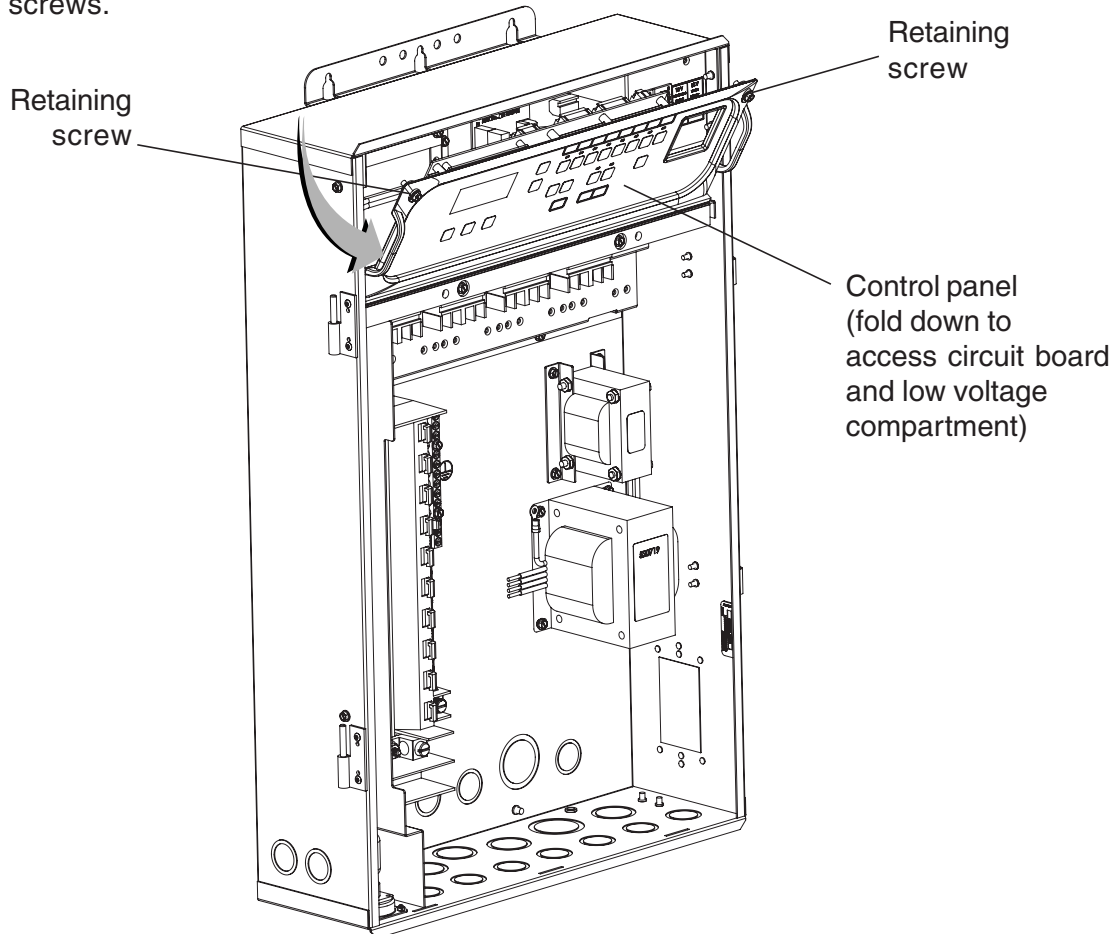

Load Center (front view)
(front door and high voltage compartment panel removed)

Connecting EasyTouch System Relays

The EasyTouch system Load Center includes four or eight pre-installed relays. To connect the pre-installed relay cable plugs to the EasyTouch circuit board:

- Route each of the power relay cable plugs up into the low voltage compartment to the EasyTouch circuit board. Insert the relay plugs into the two-pin sockets on the circuit board, beginning with **FLTR PUMP**, then **AUX1**, **AUX2**, **AUX3**, and **AUX4**. For the actuator two-pin socket locations, see below. For the EasyTouch system wiring diagram, see page 31 or the load center front door inside panel.

Note: Install the optional Two-Speed Pump relay (P/N 520198) cable plug into the 2SPD two-pin socket on the EasyTouch circuit board. For installation and operation information, refer to the Two-Speed Relay User's Guide (P/N 520210).

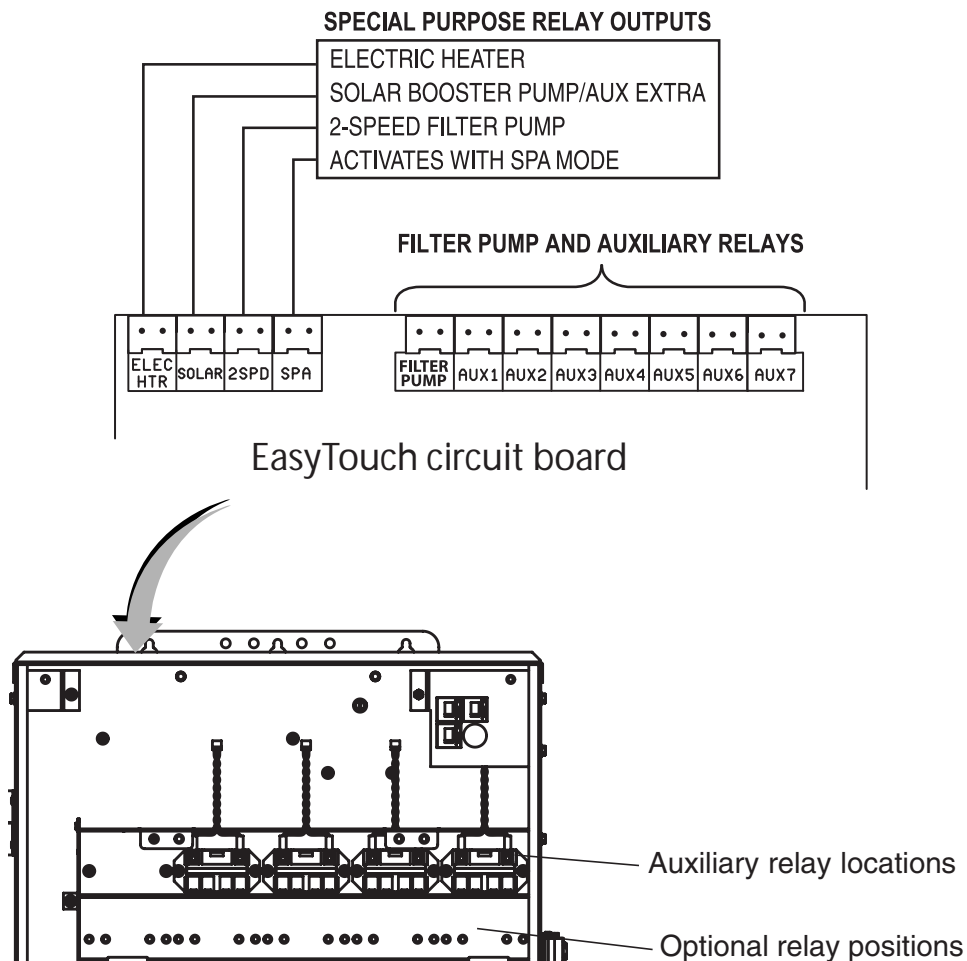

Connecting IntelliTouch System Relays

There are five (5) pre-installed relays in the IntelliTouch Load Center and Power Center. To connect the pre-installed relay cable plugs to the IntelliTouch Personality circuit board:

- Route the power relay cable plugs up into the low voltage compartment to the Personality circuit board. Insert the plug into the two-pin sockets, beginning with **FLTR PUMP**, then **AUX1**, **AUX2**, **AUX3**, and **AUX4**. For the two-pin socket locations, refer to the diagram shown below. For IntelliTouch system wiring diagrams, see pages 41-43. Note: **For optional relays**; insert each optional auxiliary relay plug into the one of the two-pin sockets, beginning with **AUX5**, **AUX6**, **AUX7** and **AUX8**.
- Dual Equipment: Pool and Spa with Dual Sets of Equipment** – The IntelliTouch i10+3D (P/N 521222) is designed to operate two sets of pool equipment. Each set of a equipment (Pool or Spa) can control one temperature setting. This IntelliTouch Personality Kit can control up to 10 pumps and/or lighting circuits, plus two heater circuits. The Personality Kit includes, eight auxiliary circuits plus a filter pump.
- Single Equipment: Pool Only or Spa Only Applications** – The IntelliTouch i5S+3 (P/N 521223) and i9+3S provide advanced automation for a single body of water. The i5S+3 Personality Kits includes four auxiliary circuits plus filter pump operation. Five relays are included in the Load Center. The i9+3S (P/N 521224) Personality Kits includes eight auxiliary circuits plus filter pump operation and the +3 option (create a Feature Macro circuit for valve actuators without using an existing output aux circuit). Four relays are included in the Personality kit and five in the Load Center. You can create a Feature circuit for valve actuators without using an existing output auxiliary circuit, and special light functions for color lighting. This model also allows HI-TEMP and LO-TEMP settings.

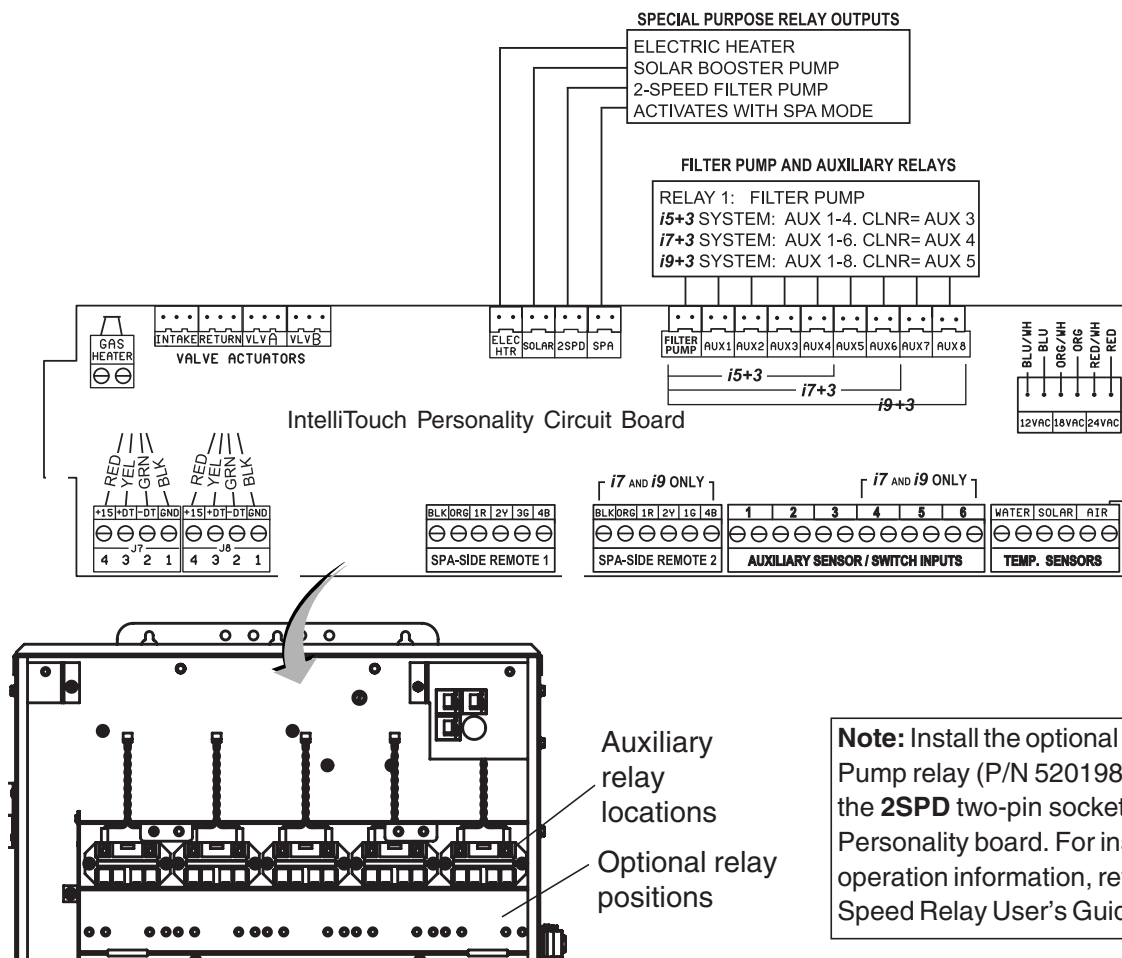

Installing Valve Actuators

The EasyTouch and IntelliTouch automation control system can control up to four automatic valve actuators. Two of the valve outputs are dedicated to the pool/spa intake (INTAKE) and return (RETURN) valves. Valve A or Valve B actuators are for general purpose use (solar, water-feature, in-floor cleaner, etc.). Using the IntelliTouch Valve Expansion Board, an addition three actuators can be added to the IntelliTouch Personality circuit board (for more information, see next page). For EasyTouch and IntelliTouch shared equipment systems there are two motorized valve actuators (CVA-24T, P/N 263045) provided in the kit.

To install the valve actuator (two-way valve example shown):

1. Remove the valve knob, handle and the four screws, from the valve cover (indicated with arrows).
2. Align the splines of the actuator shaft over the shaft of the valve.
3. If the actuator is not aligned with the mounting holes on the valve cover, rotate the actuator (while still attached to the valve) until the actuator is positioned correctly over the valve.
4. Secure the actuator with the screws provided. Only use self-tapping screws when required.
5. Mount the valve handle and knob onto the actuator.

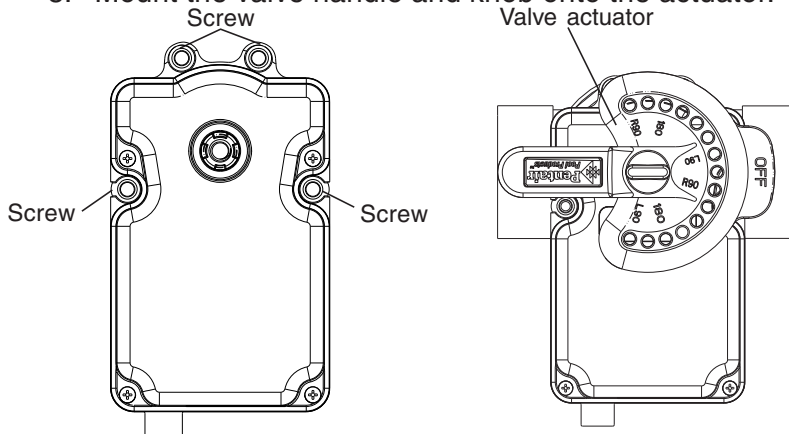

Adjusting the valve position (3-way valve shown below)

If the valve rotates to the wrong position, adjust the switch on the back of the actuator between ON1 and ON2 positions. This will rotate the valve to the correct position. The following diagram shows the standard plumbing and valve actuator position.

Valve Handle Operation: To reposition the valve handle: Rotate the handle to the desired “OFF” position. The diverter valve handle OFF indicator, represents the current position of the valve’s internal diverter seal which will stop the flow of water. The valve handle stop-pins determine the position of the diverter valve’s internal seal to stop or allow water flow. Note: When a motorized valve actuator is installed, stop-pins are not required.

Handle Stop-Pins Positions: The two movable stop-pins can be set to allow the valve handle’s position to completely stop the flow of water, regulate a limited flow, or allow the maximum flow. To set the stop-pins: Insert the stop-pins in the pin holes according to the corresponding “degree indicator” displayed on top of the handle. The stop-pin positions can be set to 180°, L90° (left-side) and R90° (right side). Repositioning of either stop-pins allows the handle to be set to any desired percentage of water flow.

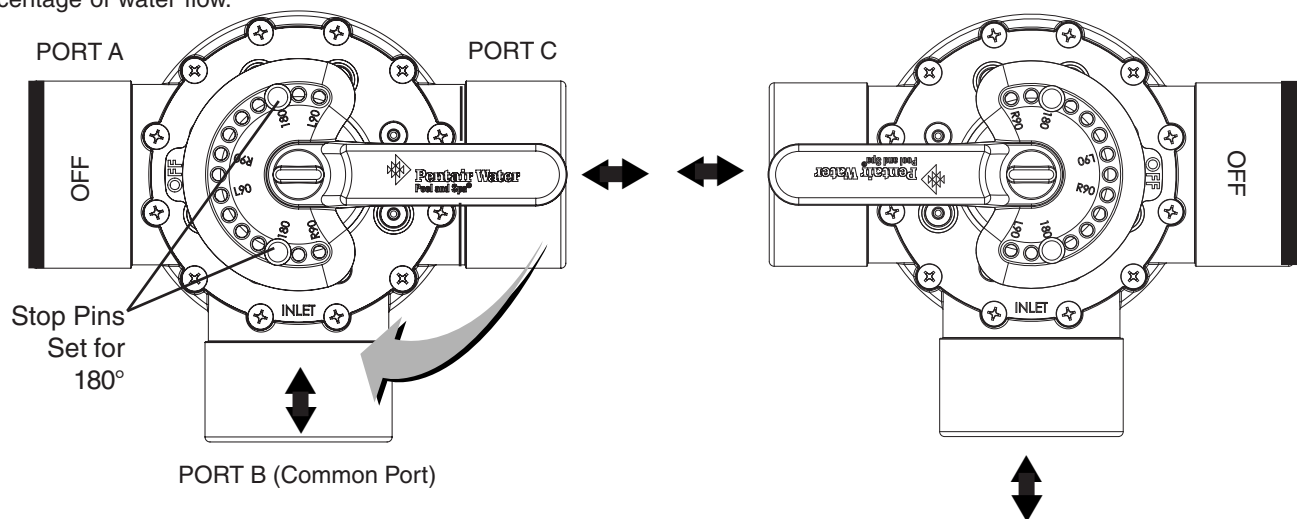

6. At the Load Center or Power Center, route the cable up through the 1" grommet and low voltage raceway to the circuit board (see page 3).

7. **EasyTouch Circuit Board:** Connect the Valve A actuator cable plug into the **INTAKE** (suction) 3-pin socket, and Valve B actuator cable plug into the **RETURN** three-pin socket on the right side of the EasyTouch circuit board. Excess cable can be coiled in the enclosure low voltage raceway left side compartment (see page 3). Do not coil the conductor in upper low voltage compartment. For valve actuator circuit board socket location see above and page 31. For plumbing requirements, see Item 2 and 3 on page 44.

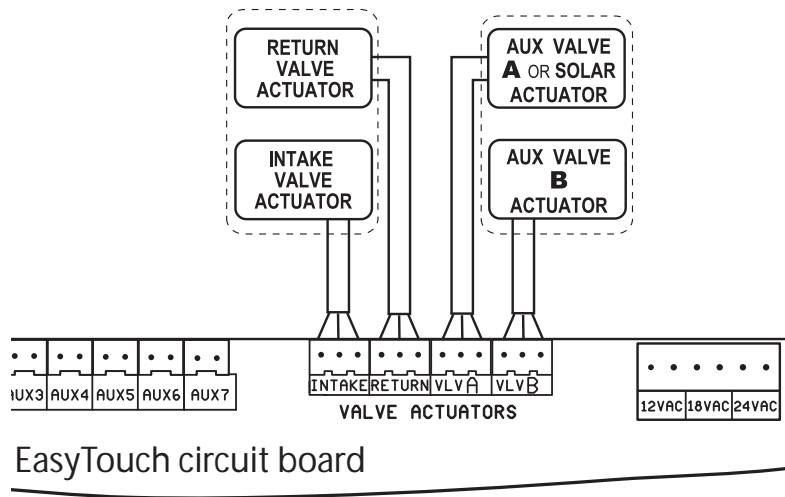

IntelliTouch Personality: Connect the Valve A actuator cable plug into the **INTAKE** (suction) 3-pin socket, and Valve B actuator cable plug into the **RETURN** three-pin socket on left side of the Personality circuit board. Excess cable can be coiled in the enclosure low voltage raceway left side compartment. Do not coil the conductor in upper low voltage compartment. For valve actuator circuit board socket location see below and pages 41-42. For plumbing requirements, see Item 2 and 3 on page 44.

IntelliTouch Optional Valve Module Expansion Board: Using a Valve Module Expansion board (P/N 520285), three additional valve actuators (VALVE C, D and E) can be added to the system. The expansion board attaches to the edge of the IntelliTouch Personality board. For installation and operation information, refer to the IntelliTouch Valve Actuator Installation Guide (P/N 520294).

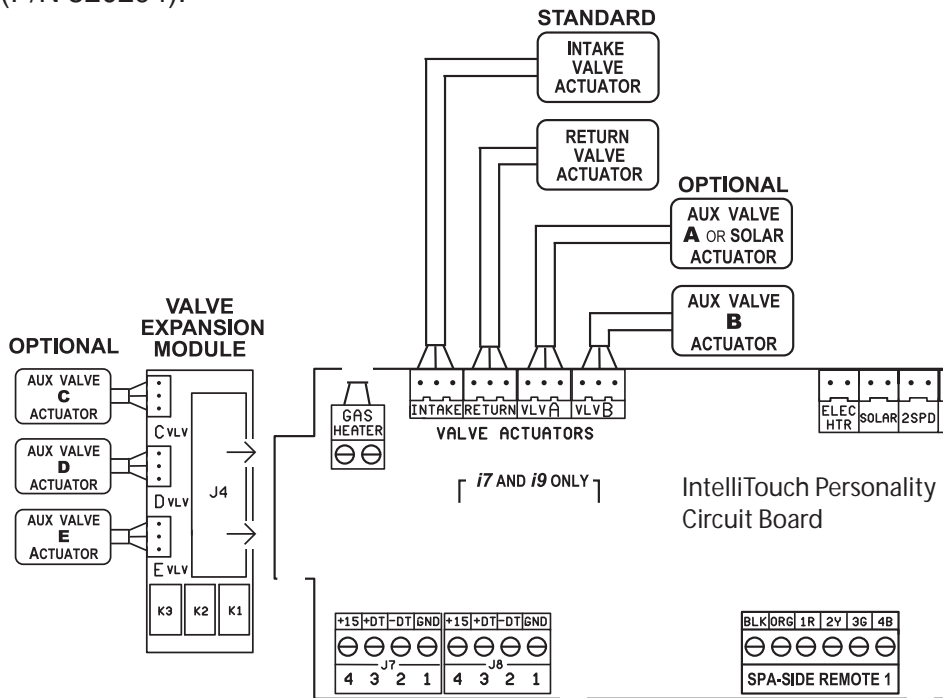

IntelliTouch Personality Circuit Board

Installing and Connecting Temperature Sensors

Water Temperature Sensor

To install the water sensor:

1. Select a convenient location to mount the water sensor in the plumbing system between the filter pump and filter. Drill a 5/16" diameter hole in one side of the pipe,
2. Insert tip of sensor into the hole. Use the band clamp to secure the sensor to the pipe. Tighten the clamp just enough so that the o-ring begins to flatten. Do not overtighten
3. Fasten the cable to the plumbing with cable ties.
4. Run 22 AWG two-conductor cable (included in kit) between the sensor and the enclosure. Route the cable up through the low voltage raceway to the circuit board.
5. Cut off the excess conductor and the strip conductors ¼ inch. Use waterproof connectors (provided) to connect the sensor to cable.

EasyTouch System: Insert the conductors into the **WATER SENSOR** screw terminals (**J21**) on right-side of the motherboard. For sensor circuit board screw terminal location (see below and page 31).

IntelliTouch System: Insert the conductors into the **WATER SENSOR** screw terminals (**J5**) on right-side of the Personality circuit board. For sensor circuit board screw terminal location (see below and pages 41 and 42).

Ambient Air Temperature Sensor (for freeze protection)

To install the air sensor:

1. Mount the sensor in the open air, in a shaded area, away from air conditioners. During the winter months, to avoid freeze damage to pool and spa equipment, mount the air sensor in a shaded area to assure proper temperature readings. The main screen displays the current ambient air temperature.
2. Fasten the cable to the plumbing with cable ties.
3. Run 22 AWG two-conductor cable (included in kit) between the sensor and the enclosure. Route the cable up through the low voltage raceway to the circuit board.
5. Cut off the excess conductor and the strip conductors ¼ inch. Use waterproof connectors (provided) to connect the sensor to cable.

EasyTouch System: Insert the conductors into the **AIR** screw terminals (**J21**) on right side of the EasyTouch circuit board. For sensor circuit board screw terminal location (see below and page 31).

IntelliTouch System: Insert the conductors into the **AIR** screw terminals (**J5**) on right side of the Personality circuit board. For sensor circuit board screw terminal location, see below and pages 41 and 42.

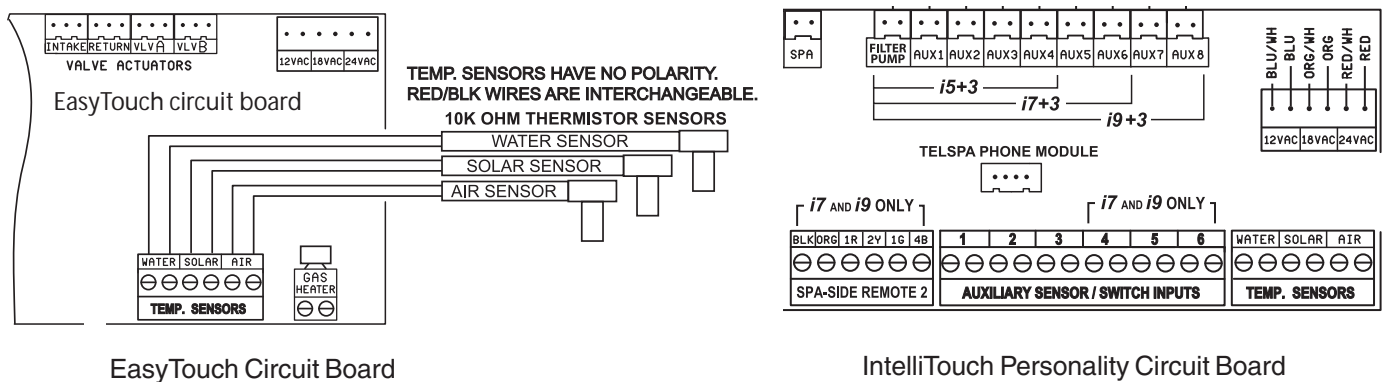

Solar Temperature Sensor (Optional)

Run a two-conductor cable between the sensor and the EasyTouch circuit board in the Load Center.

To install the solar sensor:

- 1 Mount the sensor on a flat surface, with the same exposure to sun as the solar collectors (next to the collectors is recommended) or any sunny location. Do not let the sensor touch the panels. **WARNING: DO NOT DRILL HOLE AND CLAMP SENSOR INTO SOLAR PIPE.** For glazed panels, install the sensor between collector and glazing.
- 2 If necessary, splice a two-conductor extension conductor to the sensor. Run two-conductor cable between the sensor and the enclosure. Use waterproof connectors to connect the sensor to the cable. Use twisted pair 20 AWG outdoor rated sensor wiring and be sure the conductor connections are protected from the environment. Use shielded cable for long runs or runs near other electrical wiring.
3. Cut off the excess conductor and the strip back conductors ¼ inch. Use waterproof connectors (provided) to connect the sensor to cable.

EasyTouch System: Insert the conductors into the **SOLAR SENSOR** screw terminals (**J21**) on right side of the EasyTouch circuit board. For sensor circuit board screw terminal location (see below and page 31).

IntelliTouch System: Insert the conductors into the **SOLAR SENSOR** screw terminals (**J5**) on right side of the Personality circuit board. For sensor circuit board screw terminal location (see below and pages 41 and 42).

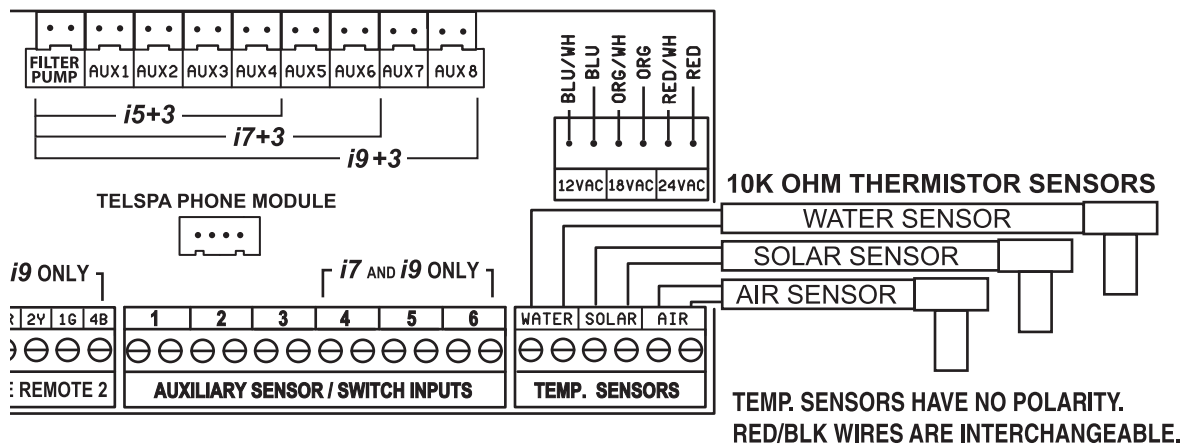
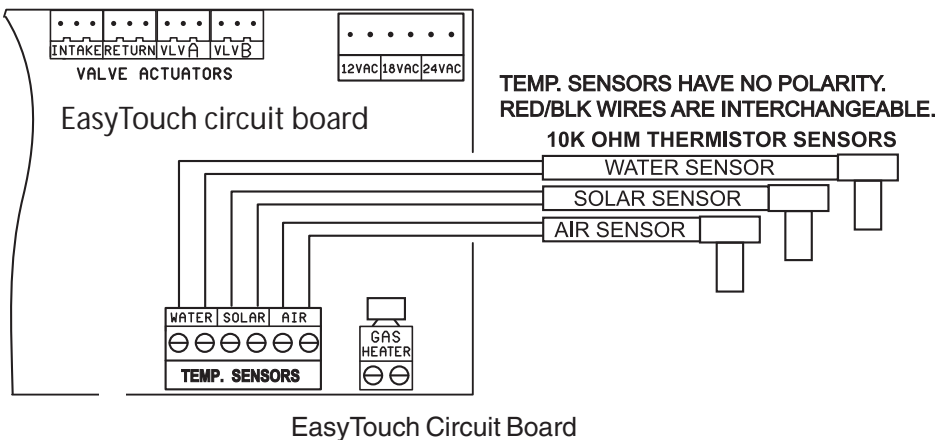

Connecting a Standard Gas Heater (EasyTouch and IntelliTouch System)

For EasyTouch and IntelliTouch heater control, there are low voltage dry contacts that can be connected to most gas heaters or heat pumps with 24 VAC control circuits. The following connection instructions are for gas heaters and heat pumps with low voltage thermostats.

To connect the heater thermostat cable plug to the EasyTouch or IntelliTouch circuit board:

1. Switch the power OFF to the heater.
2. Remove the factory installed jumper from the heater's "Ext Switch" connector. **CAUTION IMPORTANT: DO NOT** disconnect or conductor around the thermostat, pressure switch, high limit switch, or other safety devices. At the heater, connect the conductors in accordance with heater manufacturer's instructions. For older heaters without instructions for remote operation, connect the conductors to the Fireman's switch connections in series with the thermostat, pressure switch, and other safety switches.
3. Run a two-conductor cable from the heater thermostat "Ext Switch" connector to the low voltage raceway to the Personality board in the Load Center. **NOTE:** Use 221° F (105° C) temperature rated conductor for connection to the heater. When connecting conductors inside the heater, be cautious of HOT internal parts of the heater. Refer to the minimum temperature rating for conductors recommended by the manufacturer. See the heater owners manual for details.
4. Strip back the conductors ¼ in.

EasyTouch System: Insert the conductors into the **GAS HEATER** two-screw terminals (**J19**) on the motherboard. For heater circuit board screw terminal location, see below and page 31).

IntelliTouch Personality circuit board: Insert the two conductors into the **GAS HEATER** (**J30**) two-screw terminal on the left side of the Personality circuit board. For heater circuit board screw terminal location, see below and pages 41 and 42).

CAUTION: Be sure that the conductors from the heater to the Load Center or Power Center are not near or touching any line voltage conductors in the heater. Failure to follow these instructions may cause the heater to malfunction.

5. Set the Power (Thermostat Select) switch to either "Pool" or "Spa."
6. Set the "Pool" and "Spa" thermostats to their maximum position.

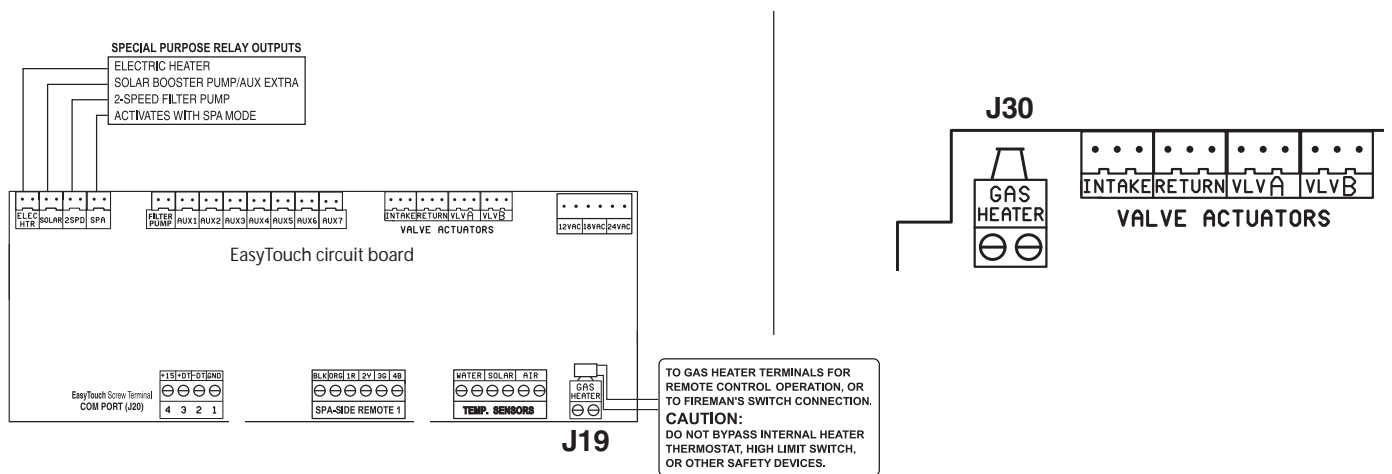

EasyTouch Circuit Board

IntelliTouch Personality Circuit Board

Wiring Pentair UltraTemp® Heat Pump

Be sure to check the UltraTemp terminal block conductor colors and pinouts (located on the back of the Auto Set board) before connecting it to the EasyTouch or IntelliTouch COM ports. The See the wiring table below for the pin configuration.

IMPORTANT: On the UltraTemp AutoSet circuit board ONLY CONNECT PIN 3 (YELLOW) and PIN 2 (GREEN) to the EasyTouch and IntelliTouch COM port pins YELLOW and GREEN respectively. Do not connect pin 1 or pin 4 on the AutoSet board or the COM port. These pins are not used.

Wiring Description

COM port wire color	Description	UltraFlo pin number and wire color
PIN 4 (RED) (DO NOT USE)	+15 VDC	PIN 4 (DO NOT USE)
PIN 3 (YELLOW)	+ DATA	PIN 3 (YELLOW)
PIN 2 (GREEN)	- DATA	PIN 2 (GREEN)
PIN 1 (BLACK) (DO NOT USE)	GROUND	PIN 1 (DO NOT USE)

Wiring Pentair IntelliFlo® Pumps

The RS-232 communication cable (provide with pump) consists of a 50 ft 22 AWG four conductor low voltage cable. The EasyTouch and IntelliTouch filter pump output is rated at 120 VAC, 15 AMP maximum. Check the electrical rating marked on the pump motor before connecting it to the system.

To connect the IntelliFlo communication cable to the Load Center or Power Center (IntelliTouch only):

1. Switch AC power OFF to the load center or power center at the main house circuit breakers.
2. Run the communication cable from the pump to the enclosure.
3. Insert the cable conductors into the one of the plastic grommet fittings, located on the lower left side of the enclosure and pull the cable up through the low voltage to the EasyTouch or IntelliTouch circuit board.
4. Strip back the outer jacket four (4) inches. Strip back each conductor a ¼-inch.
5. **EasyTouch:** Insert the conductors into the COM PORT (J20) screw terminals located on the top of the EasyTouch circuit board (see diagram below). Secure the conductors with the screws. For wiring details, refer to the pin configuration shown below. Note: Multiple conductors may be inserted into a single screw terminal.

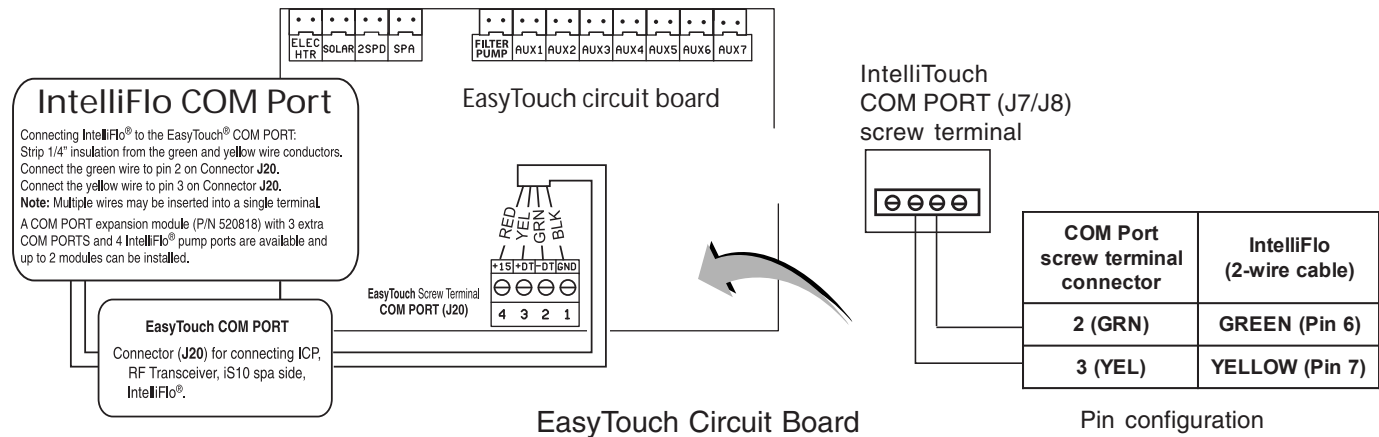

- IntelliTouch:** Insert the conductors into the either of the COM PORTS (**J7 and J8**) screw terminals located on the left side of the Personality circuit board. Secure the conductors with the screws. For wiring details, refer to the pin configuration shown below. Note: Multiple conductors may be inserted into a single screw terminal.

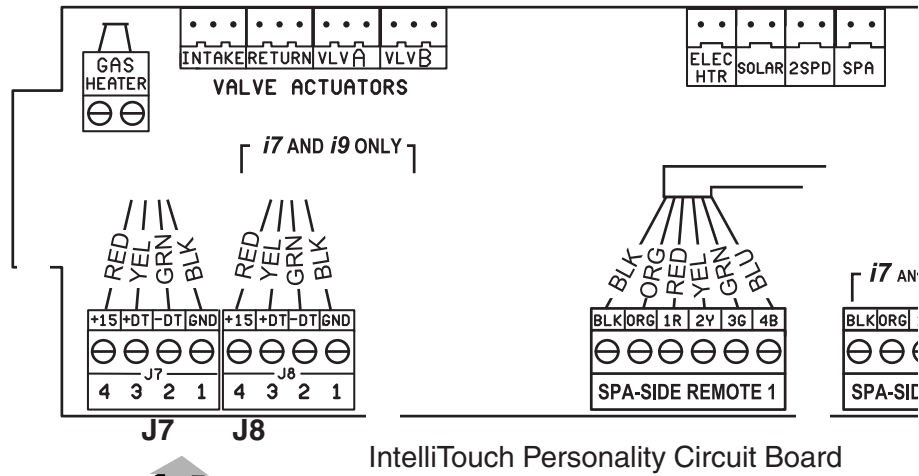

IntelliTouch
COM PORT (J7/J8)
screw terminal

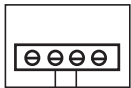

COM Port screw terminal connector	IntelliFlo (2-wire cable)
2 (GRN)	GREEN (Pin 6)
3 (YEL)	YELLOW (Pin 7)

Pin configuration

Connecting IntelliChlor (SCG) Power Cord to the Enclosure

The IntelliChlor (SCG) cell power cord is connected to the socket on the bottom of the EasyTouch or IntelliTouch enclosure. Note: **Only one IntelliChlor cell can be installed per system.**

⚠ WARNING BEFORE REMOVING THE HIGH VOLTAGE COVER PANEL FROM THE LOAD CENTER OR POWER CENTER, switch the main power **OFF** into the home at the main circuit breaker box and also switch **OFF** the main power to the Load Center or Power Center.

⚠ WARNING TO AVOID AN ELECTRICAL HAZARD AND EQUIPMENT DAMAGE TO THE ENCLOSURE AND INTELLICHLOR CELL: FIRST DISCONNECT AC POWER TO THE ENCLOSURE BEFORE CONNECTING THE INTELLICHLOR CELL POWER CABLE TO THE ENCLOSURE SOCKET.

To connect the IntelliChlor power cord to the Load Center or Power Center (IntelliTouch only):

1. **Switch AC power OFF** to the Load Center or Power Center.
2. Align the four pins of the IntelliChlor cell power cord connector with the socket on the bottom of the enclosure and insert the cord connector into the socket.
3. Rotate the socket nut until it locks the connector in place. Do not over tighten the nut (hand tighten only).
4. Switch AC power ON to the load center.

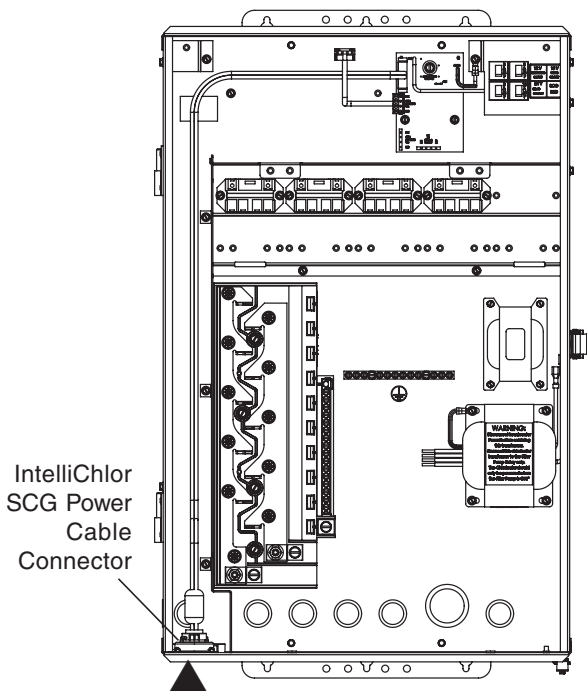

IntelliChlor
SCG Power
Cable
Connector



Connector
socket nut

To IntelliChlor cell

EasyTouch/IntelliTouch Load Center
(with IntelliChlor SCG option)

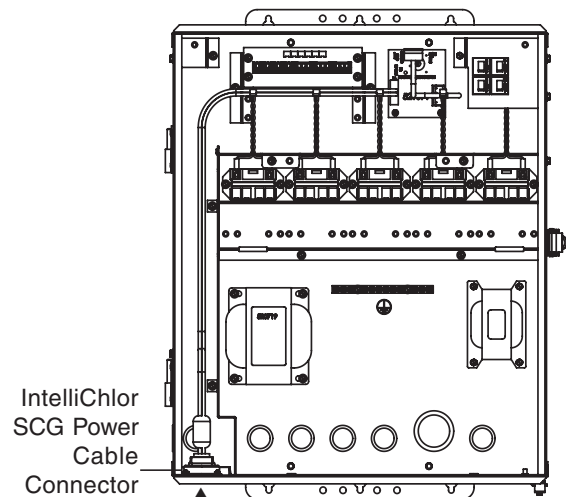

IntelliChlor
SCG Power
Cable
Connector



Connector
socket nut

To IntelliChlor cell

IntelliTouch Power Center
(with IntelliChlor SCG option)

Connecting IntelliChlor (SCG) COM Port Cable

The IntelliChlor (SCG) communicates from the EasyTouch and IntelliTouch circuit board to the IntelliChlor (SCG) circuit board via an RS-485 communications four conductor, 22 AWG or larger cable. This cable (provided in kit) connects to both the IntelliChlor (SCG) circuit board COM port terminal and the EasyTouch or IntelliTouch circuit board COM port.

⚠ WARNING TO AVOID AN ELECTRICAL HAZARD AND EQUIPMENT DAMAGE TO THE ENCLOSURE AND INTELLICHLOR CELL: FIRST DISCONNECT AC POWER TO THE ENCLOSURE BEFORE CONNECTING THE INTELLICHLOR COMMUNICATION CABLE.

To connect the IntelliChlor (SCG) COM port cable (see page 22 for connector pinouts/color match):

1. **Switch AC power OFF** to the enclosure at the main house panel circuit breaker.
2. Loosen the two retaining screws securing the EasyTouch or IntelliTouch control panel. Lower the control to allow access the low voltage compartment behind the control panel circuit board as shown below.
3. **EasyTouch circuit board:** Connect the cable to COM port #1 on the IntelliChlor (SCG) circuit board. Connect the other end of the cable to the EasyTouch COM port (**J20**) screw terminal located on the top of the EasyTouch circuit board (see screw terminal location on next page). Note: Any of the three COM ports on the EasyTouch circuit board can be used for the IntelliChlor (SCG).
IntelliTouch Personality circuit board: Connect the cable to COM port #1 on the IntelliChlor (SCG) circuit board. Connect the other end of the cable to either of the COM ports (**J7 and J8**) screw terminals located on the left side of the Personality circuit board (see screw terminal location on next page).
4. After electrical connections have been completed, close the control panel and tighten the two retaining screws.
5. **Switch AC power ON** to the load center.

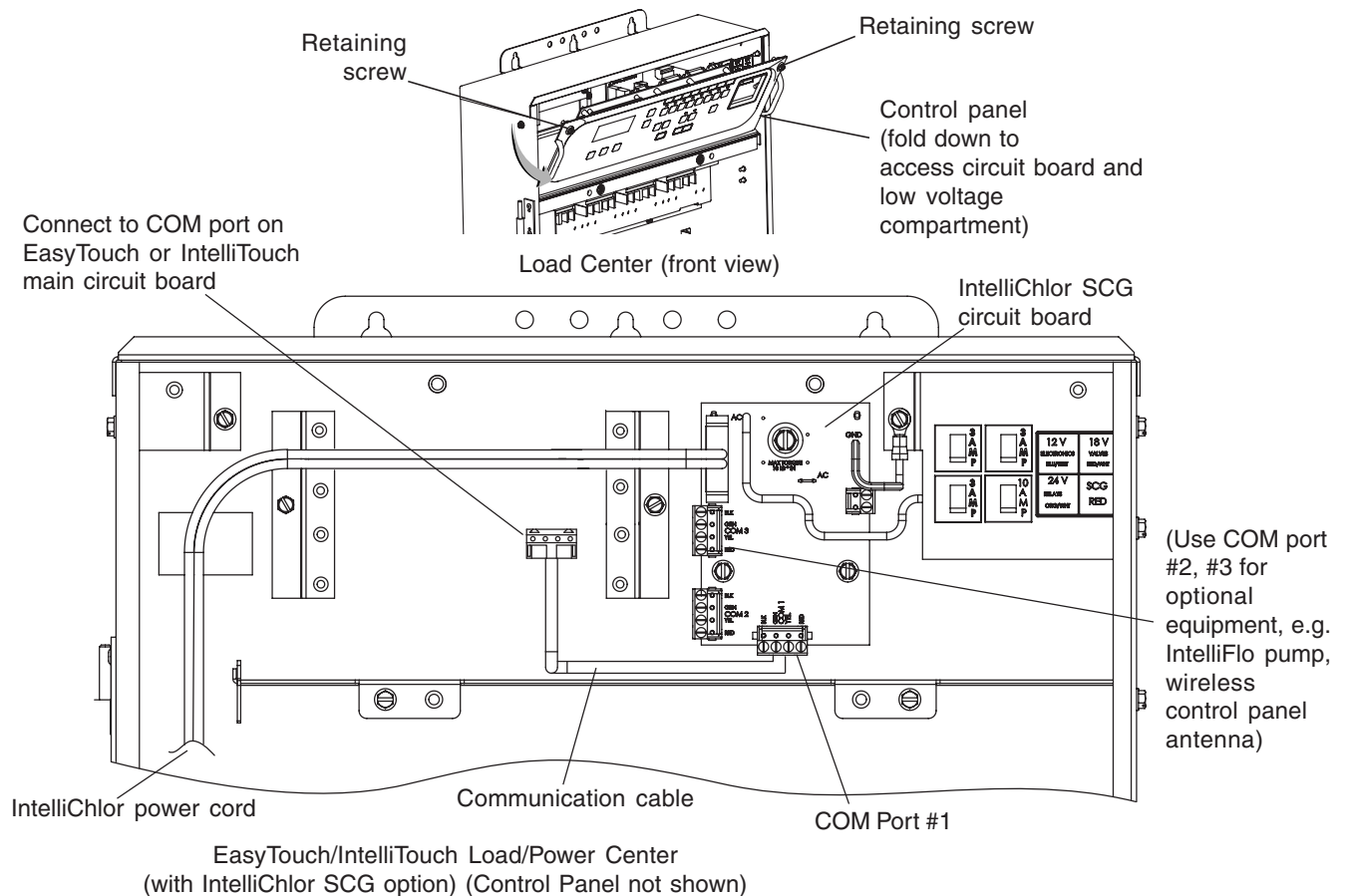

Connecting IntelliChlor (SCG) COM Port Cable (continued)

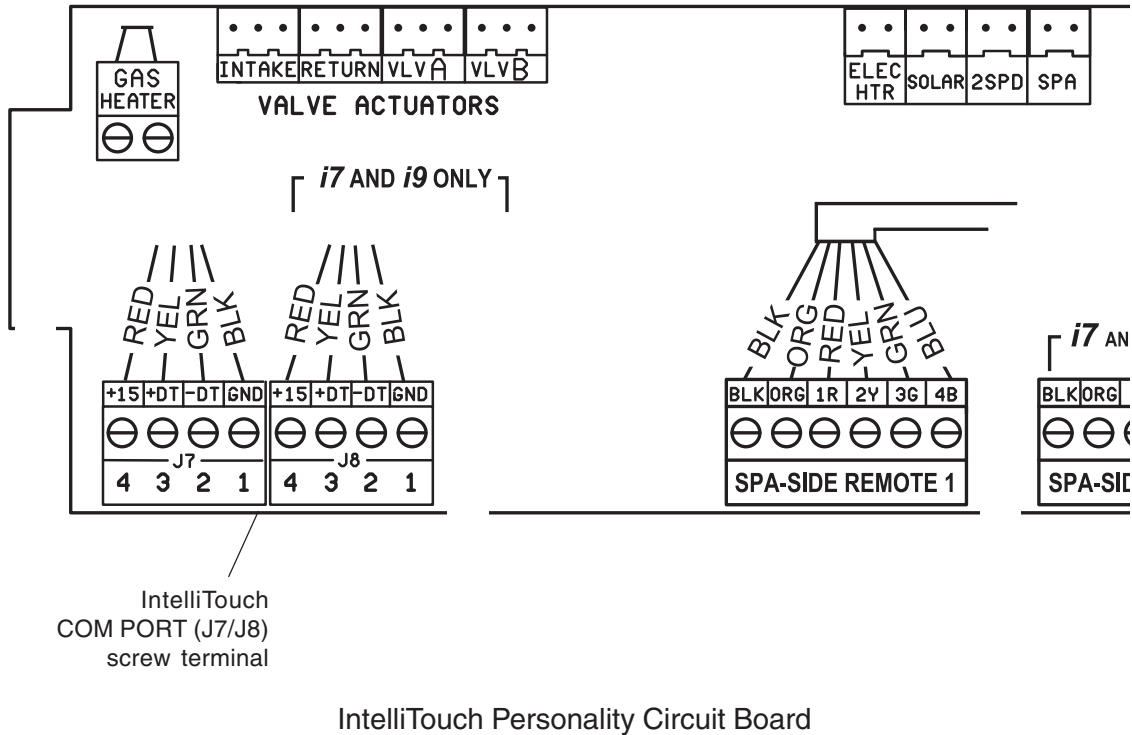
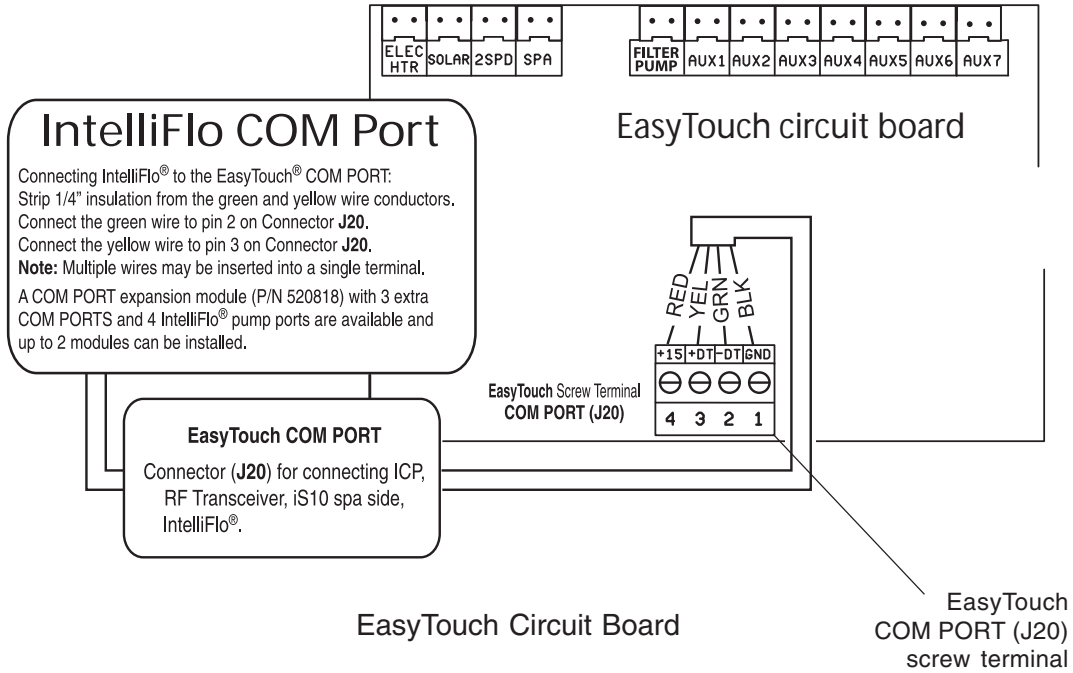

Wiring a Salt Chlorine Generator

Be sure to check each conductor color between the salt chlorine generator and the EasyTouch, or IntelliTouch load/power center as shown in the following wiring tables.

Commonly used salt chlorine generator wiring is shown but you should still verify with the manufacturers documentation. Failure to connect the salt chlorine generator properly can permanently damage the EasyTouch and IntelliTouch system and/or salt chlorine generator.

Wiring Description

(EasyTouch, IntelliTouch COM Port to the IntelliChlor SCG Circuit board COM Port)

SCG COM Port wiring color connection	Description	From IntelliChlor Power Center COM Port
RED	+15 VDC	RED
YELLOW	+ DATA	YELLOW
GREEN	- DATA	GREEN
BLACK	GROUND	BLACK

Wiring Description

(Hayward® or Jandy® Load Center COM Port)

Hayward® or Jandy® Load Center COM port wiring color connection	Description	IntelliChlor Salt Chlorine Generator
RED	+15 VDC	RED
YELLOW	+ DATA	BLACK
GREEN	- DATA	YELLOW
BLACK	GROUND	GREEN

Wiring IntelliChem®

Be sure to check each conductor color between IntelliChem and the EasyTouch or IntelliTouch load/power center as shown in the following wiring table.

Wiring Description

(IntelliChem COM Port to EasyTouch and IntelliTouch COM Port)

IntelliChem COM Port (J7) wiring color connection	Description	From EasyTouch or IntelliTouch COM Port
RED	+15 VDC	RED
YELLOW	+ DATA	YELLOW
GREEN	- DATA	GREEN
BLACK	GROUND	BLACK

Wiring IntelliChlor (SCG) Transformer to Filter Pump Relay

IMPORTANT! IntelliChlor (SCG) AC transformer wiring Instructions: When using the EasyTouch or IntelliTouch automation control system with the IntelliChlor (SCG) option, be sure the IntelliChlor (SCG) AC transformer conductors are connected to the PUMP SIDE OF THE MAIN FILTER PUMP RELAY located in the enclosure (see page 25). This ensures that the IntelliChlor cell produces chlorine only when the main filter pump is on. This method does not require a ground fault circuit-interrupter (GFCI) for the IntelliChlor power center.

WARNING BEFORE REMOVING THE HIGH VOLTAGE COVER PANEL FROM THE LOAD CENTER OR POWER CENTER, switch the main power **OFF** into the home at the main circuit breaker box and also switch **OFF** the main power to the Load Center or Power Center.

WARNING TO AVOID AN ELECTRICAL HAZARD AND EQUIPMENT DAMAGE TO THE ENCLOSURE AND INTELLICHLOR CELL: FIRST DISCONNECT AC POWER TO THE ENCLOSURE BEFORE CONNECTING THE INTELLICHLOR COMMUNICATION CABLE.

To connect the IntelliChlor (SCG) transformer conductor to the main filter pump relay:

1. **Switch AC power OFF** to the enclosure at the main house panel circuit breaker.
2. Loosen the two retaining screws securing HIGH VOLTAGE FRONT COVER PANEL. Remove the panel from the enclosure (see illustration below).
3. **Locate the MAIN FILTER PUMP RELAY. Connect the IntelliChlor SCG transformer conductors to the LOAD SIDE of the relay as shown on page 25.**
4. After electrical connections have been completed, install the HIGH VOLTAGE FRONT COVER PANEL and tighten the two retaining screws to secure in place.
5. **Switch AC power ON** to the enclosure.

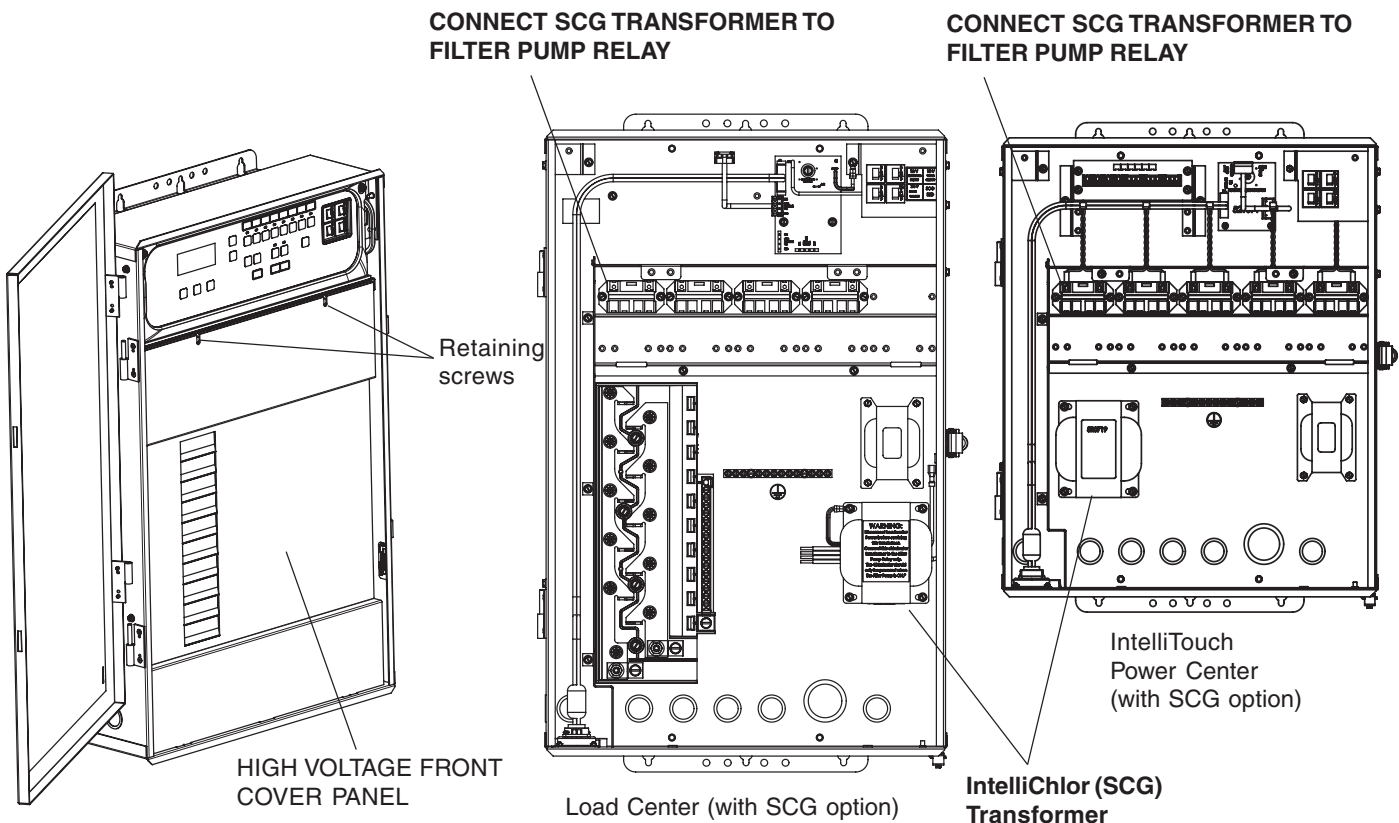

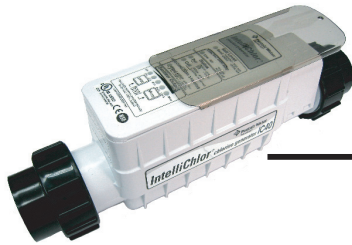

AC power cord connects to IntelliChlor SCG circuit board in enclosure)



IntelliFlo pump connects to EasyTouch or IntelliTouch COM port



2-SPD Filter Pump (wired for 120 or 240 VAC)

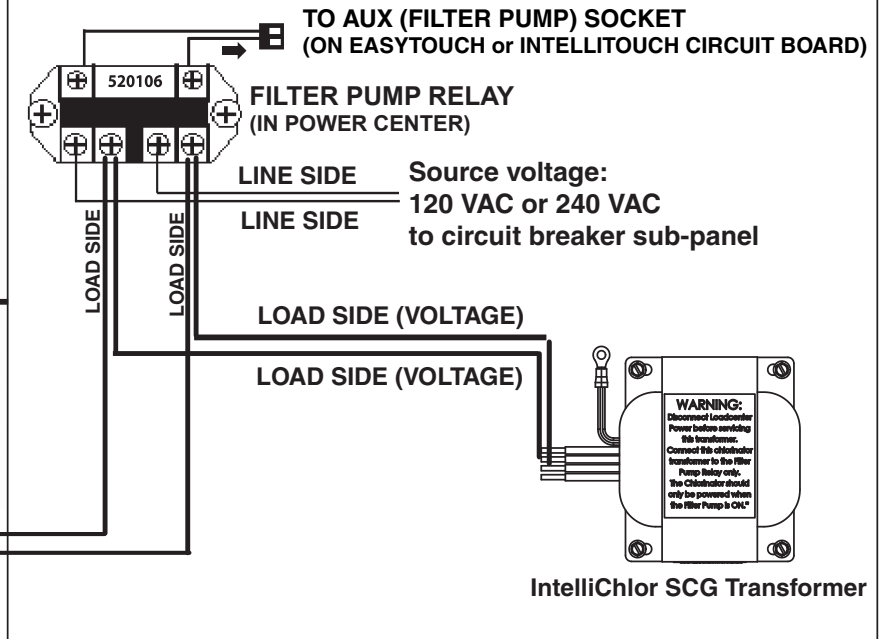
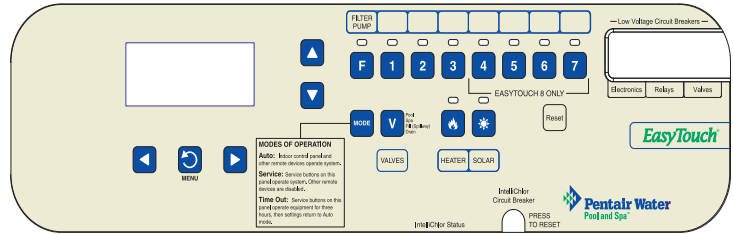

EasyTouch or IntelliTouch Load/Power Center

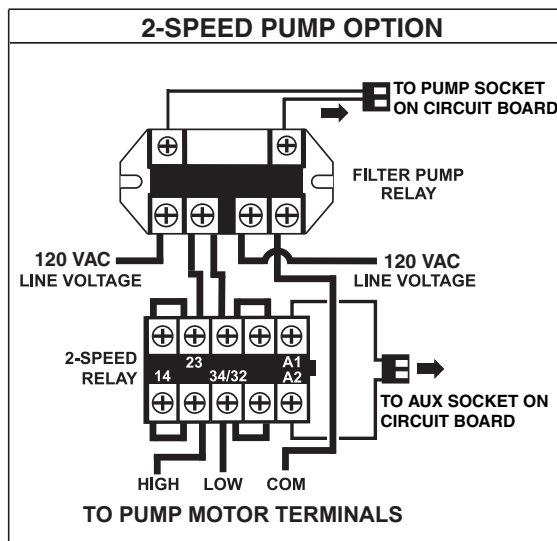

IntelliChlor and Automation Load Center Connection Diagram

Rewiring the IntelliChlor SCG Transformer for 120VAC

The IntelliChlor power supply transformer located in the Load Center and Power Center can be wired for 240 VAC at 1AMP (factory installed) or 120 VAC at 2AMP 50/60 Hz. The IntelliChlor transformer is pre-wired at the factory for 240 VAC service.

To rewire the IntelliChlor transformer and for 120 VAC:

⚠ WARNING **BEFORE REMOVING THE HIGH VOLTAGE COVER PANEL FROM THE LOAD CENTER OR POWER CENTER ENCLOSURE** switch the main power **OFF** into the home at the main circuit breaker box and also switch **OFF** the main power to the Load Center and Power Center.

1. **Switch the power OFF** to the Load Center and Power Center.
2. Unlatch the front door latch and open the front door.
3. Remove the two (2) retaining screws securing the high voltage cover-panel. Remove the **HIGH VOLTAGE COVER PANEL** from the enclosure (see illustration on page 5).
4. Rewire the Transformer for 120 VAC as shown in the wiring diagram below.
5. Install the high voltage cover panel and secure it with the two retaining screws.
6. Close the enclosure front door and secure with the latch.

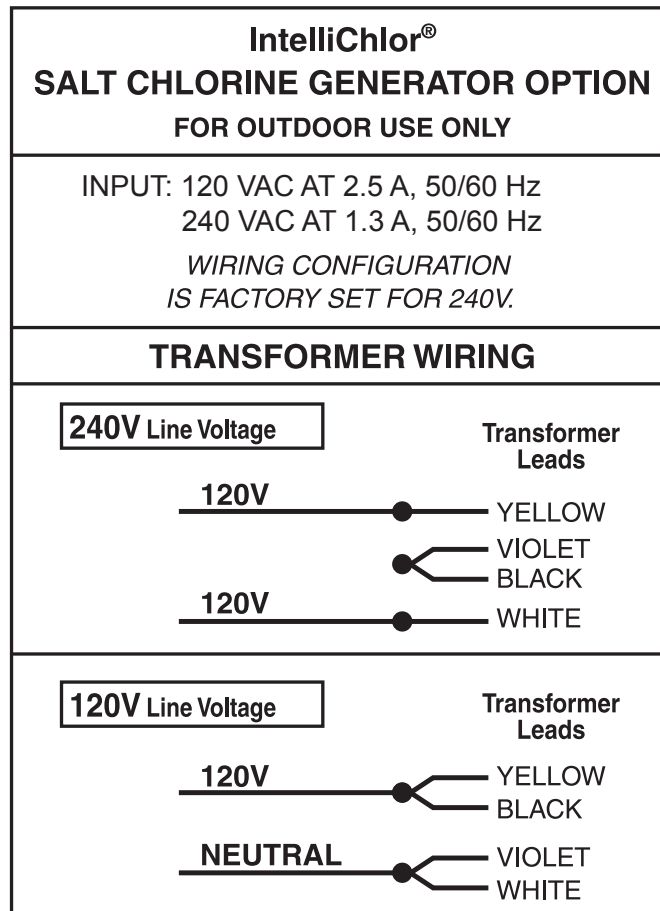

Rewiring the System Transformer for 240 VAC

The EasyTouch and IntelliTouch Load Center and Power Center system transformer can be wired for 120 VAC at 2AMP 50/60 Hz (factory installed) or 240 VAC at 1AMP 50/60 Hz. The system transformer is pre-wired at the factory for 120 VAC service.

To rewire the system transformer and for 240 VAC:

WARNING BEFORE REMOVING THE HIGH VOLTAGE COVER PANEL FROM THE LOAD CENTER OR POWER CENTER ENCLOSURE switch the main power OFF into the home at the main circuit breaker box and also switch OFF the main power to the Load Center and Power Center.

1. **CAUTION! Switch the power OFF to the Load Center and Power Center.**
2. Unlatch the front door latch and open the front door.
3. Remove the two (2) retaining screws securing the high voltage cover-panel. Remove the HIGH VOLTAGE COVER PANEL from the enclosure (see illustration on page 5).
4. Rewire the system transformer for 240 VAC as shown in the wiring diagram below.
5. Install the high voltage cover panel and secure it with the two retaining screws.
6. Close the enclosure front door and secure with the latch.

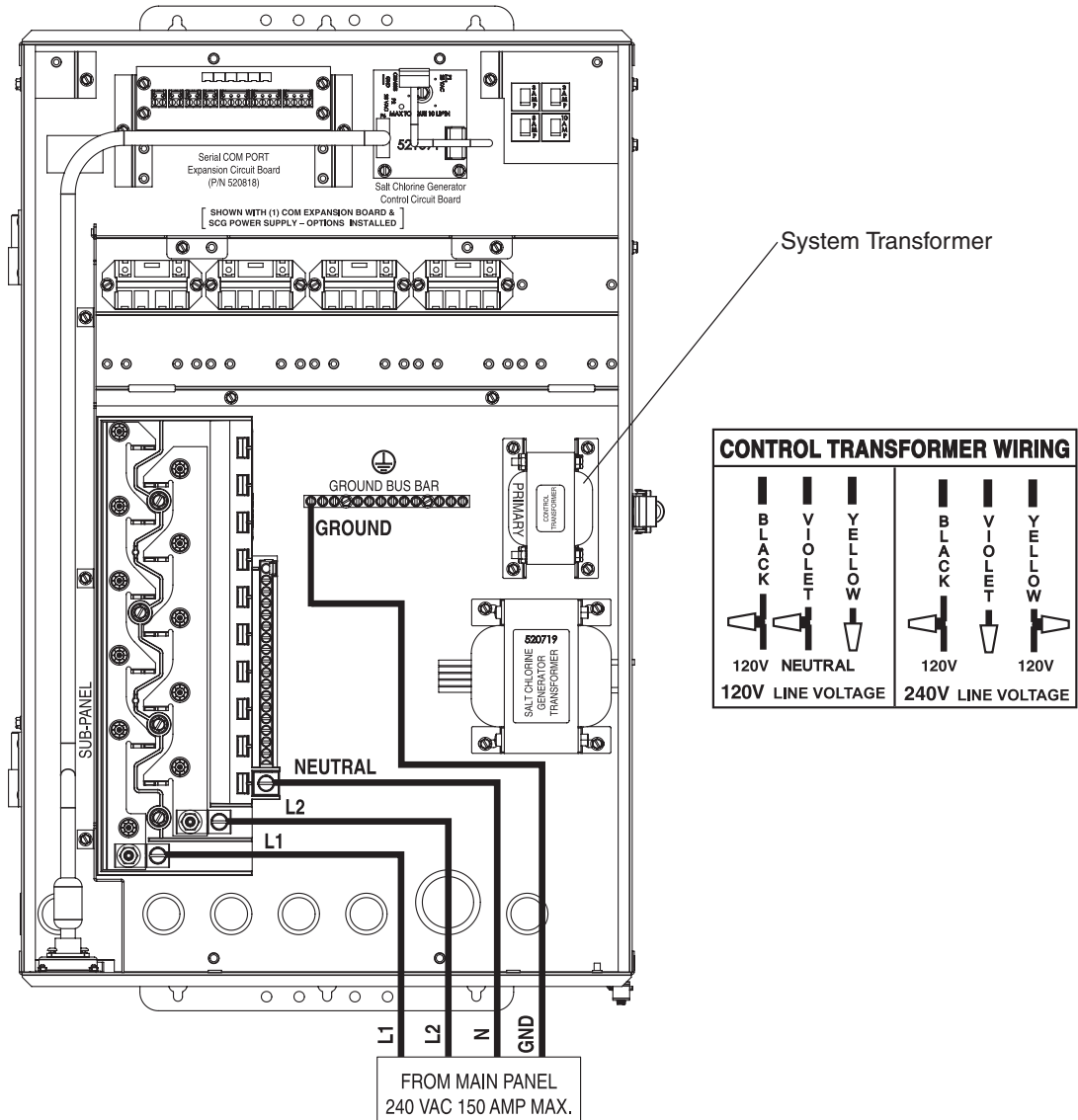

Section 2

EasyTouch® System Overview

EasyTouch® 8 and 4 Pool and Spa Control System Kit Contents

The following items are included in the EasyTouch® 8 and EasyTouch 4 control system kit which may also include the optional IntelliChlor cell.

- EasyTouch control panel (mounted in the load center)
- EasyTouch load center enclosure
- Two motorized valve actuators (CVA-24T P/N 263045) - Not included with single-body system
- Water sensor with 25 foot cable, o-ring and hose clamp (P/N 520272)
- Air sensor with 25 foot cable (P/N 520272)
- EasyTouch 8 and EasyTouch 4 Pool and spa Control System Installation Guide (this manual)

Optional Equipment

- IntelliChlor® Electronic Chlorine Generator Electrolytic Cell model IC20 (P/N 520554) or IC40 (P/N 520555)
- IntelliChem® no-pump (P/N 521357), one-pump (P/N 521356), two-pump (P/N 521355)
- IntelliChlor User's Guide (P/N 520589)
- For EasyTouch system operating instructions, refer to the EasyTouch User's Guide (P/N 521044)

EasyTouch Accessory Equipment



EasyTouch 4 Indoor Control Panel (P/N 520548)

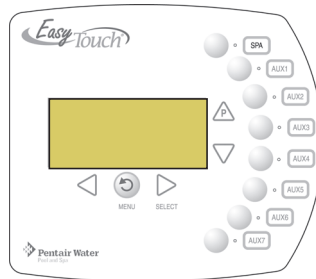

EasyTouch 8 Indoor Control Panel (P/N 520549)

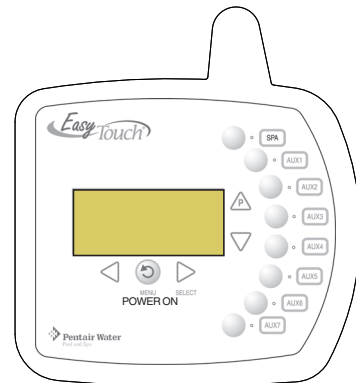

EasyTouch Wireless Control Panel (8 circuit) (P/N 520547)



SpaCommand® Spa-Side Remote Controller (P/N 521176)



QuickTouch® II wireless remote (P/N 521245)

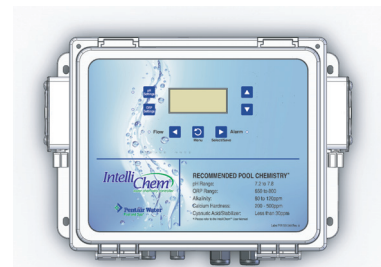

IntelliChem® Water Chemistry Controller (P/N 521356)

EasyTouch Model Part Numbers

EASYTOUCH SYSTEMS WITHOUT INTELLICHLOR TRANSFORMER BUILT-IN

520591	EasyTouch 4P - Single Body (base system - no ICP, no actuators)
520703	EasyTouch 8P - Single Body (base system - no ICP, no actuators)
520538	EasyTouch 4 - Pool/Spa (base system - no ICP, 2 actuators)
520540	EasyTouch 8 - Pool/Spa (base system - no ICP, 2 actuators)

EASYTOUCH SYSTEMS WITH INTELLICHLOR TRANSFORMER AND INTELLICHLOR CELL

520592	EasyTouch 4PSC-IC20 - Single Body (includes SCG integration & IC20 cell)
520593	EasyTouch 4PSC-IC40 - Single Body (includes SCG integration & IC40 cell)
520704	EasyTouch 8PSC-IC20 - Single Body (includes SCG integration & IC20 cell)
520705	EasyTouch 8PSC-IC40 - Single Body (includes SCG integration & IC40 cell)
520542	EasyTouch 4SC-IC20 - Pool/Spa (includes SCG integration & IC20 cell, 2 actuators)
520543	EasyTouch 4SC-IC40 - Pool/Spa (includes SCG integration & IC40 cell, 2 actuators)
520544	EasyTouch 8SC-IC20 - Pool/Spa (includes SCG integration & IC20 cell, 2 actuators)
520545	EasyTouch 8SC-IC40 - Pool/Spa (includes SCG integration & IC40 cell, 2 actuators)
521150	EasyTouch 8SC-IC60 - Pool/Spa (includes SCG integration & IC60 cell, 2 actuators)

CANADIAN EASYTOUCH SYSTEMS

520914	EasyTouch 4P-C - Single Body (salt ready system, cell must be ordered separately)
520915	EasyTouch 8-C - Pool/Spa (salt ready system, cell must be ordered separately)
520911	IntelliChlor IC20 cell for Canada
520912	IntelliChlor IC40 cell for Canada

EasyTouch Accessory Equipment

EasyTouch Wireless Control Panel, 4 circuits	(P/N 520546)
EasyTouch Wireless Control Panel, 8 circuits	(P/N 520547)
SpaCommand 10 Ten-Function Spa-Side remote, 150 ft. cable	(P/N 521176)
Two-Speed Three HP Relay up to three additional valve actuators	(P/N 520198)
Three HP Power Relay	(P/N 520106)
QuickTouch four-function wireless remote kit with transceiver assembly	(P/N 520148)
QuickTouch II four-function wireless remote kit with transceiver assembly	(P/N 521245)
IntelliChem Controller	(P/N 521356)
IntelliChlor Acid Cleaning Kit	(P/N 520670)
IntelliChlor Spacer pass-through cell for new pool start-up	(P/N 520588)

EasyTouch System Start-Up

Perform the following start-up procedures to ensure that the EasyTouch load center is installed correctly. If you need more detailed operating information, refer to the EasyTouch Pool and Spa Control System User's Guide (P/N 521044).

Before you power up the EasyTouch load center check the following:

Check Electronics

Check that the following plugs are seated correctly on the motherboard:

- Relay connectors - **FLTR PUMP - AUX1 - AUX7 (EasyTouch 8), AUX1 - AUX3 (EasyTouch 4)**
- Temperature sensors connectors **WATER, SOLAR, AIR**
- Transformer conductor harness (**J1**) attached to the motherboard.
- Heater control connector **ELEC HTR** or two-conductor screw terminal.

Refer to Summary Installation Steps (page 2) and EasyTouch System Wiring Diagrams, on page 23.

EasyTouch System Test

The following describes how to test the main control panel to activate the heater, valves and pumps. Before testing the system, be sure that all pool and spa equipment has been properly installed and connected to the EasyTouch load center.

Testing Valve Actuators and Filter Pump

Use the following steps to test the valve actuators (CVA24T) for proper rotation.

To test the valve actuators and pump:

1. Power up the EasyTouch load center.
2. Press the **Mode** button on the main control panel. The display shows "SERVICE".
3. Press the **Valve (V)** button to select **POOL**.
4. Press the **Filter Pump (F)** button to activate the filter pump. Water will be removed from the pool and returned to the pool.
5. Repeat steps 3 and 4 selecting **Fill (Spillway)** then **Drain**.
6. Set both valve actuators (CVA-24T) for suction and return. Use the toggle switch on the rear of the CVA-24T to withdraw and return water from the pool.

Note: With the filter pump operating, if the water is not being removed and returned to the pool, check that the valve actuator plugs are connected correctly on the motherboard.

Testing the auxiliary relays

Affix the auxiliary relay labels to the appropriate AUX buttons on the EasyTouch control panel to identify the connected equipment.

- Press the **Mode** button to enable "Service" pool mode. Press the Filter Pump button (LED on) and each auxiliary (AUX) circuit button, the Heater and Solar buttons to verify the functions. Press the **Mode** button twice to return the system to "**AUTO**" mode when done.

EasyTouch Circuit Board Connections

The EasyTouch system circuit board is mounted in the top of the Load Center. The circuit board provides the voltage connections to the filter pump, heater, auxiliary relays, motorized valves and for temperature sensors. The COM port on the EasyTouch circuit board provides connection to the EasyTouch indoor control panel, wireless remote transceiver, SpaCommand and iS4 spa side remote and to the IntelliFlo pump.

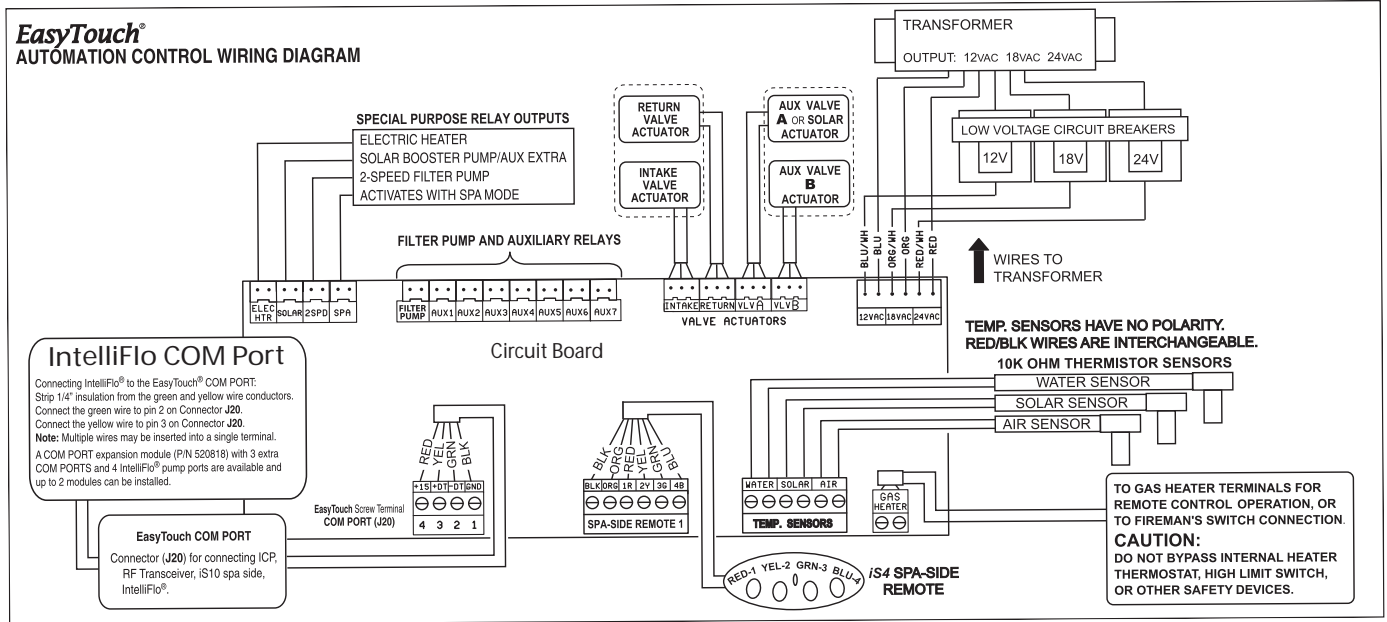

EasyTouch Outdoor Circuit Board Connections

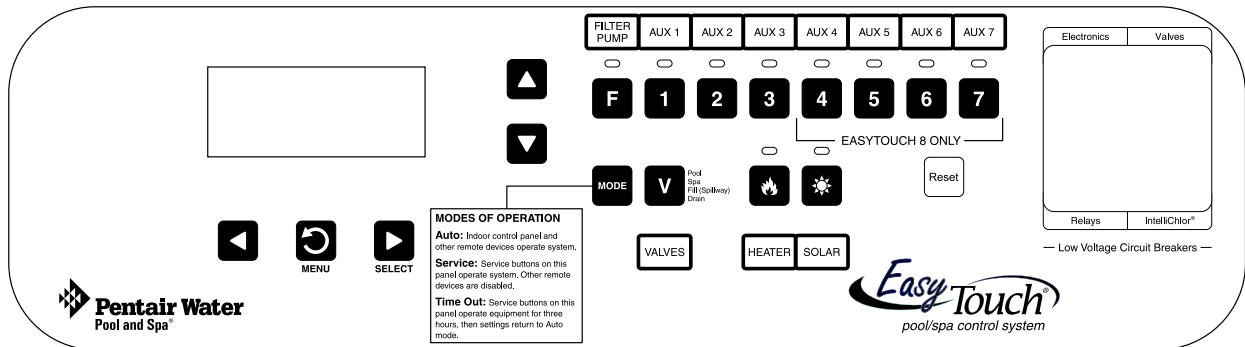

EasyTouch Outdoor Control Panel

WARNING PREVENT ELECTROCUTION DISCONNECT ALL SUPPLY CONNECTIONS BEFORE SERVICING. THIS APPLIANCE MAY HAVE UP TO 11 SUPPLY CONNECTIONS.
 INSTALL AT LEAST 5 FEET (1.2m) FROM INSIDE WALL OF POOL OR SPA.

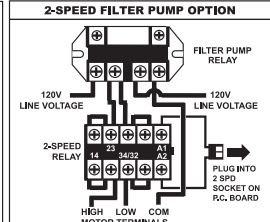
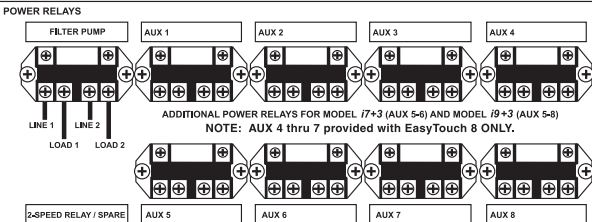
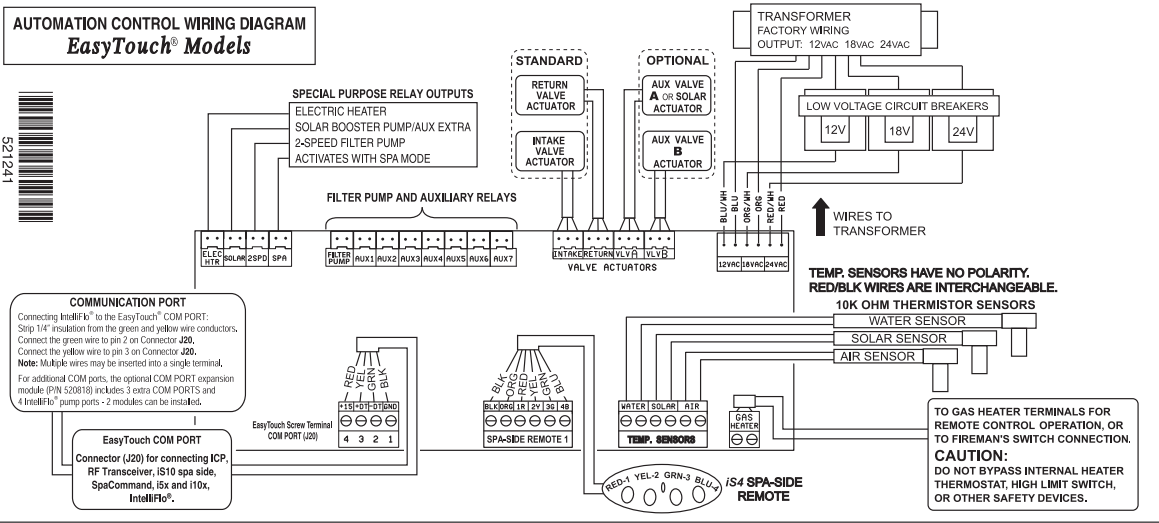

PREVENT WATER DAMAGE
KEEP DOOR CLOSED

A disconnecting means must be located within sight from the equipment and at least 5 feet (1.52 m) from the inside walls of the pool, spa or hot tub.

APPROVED BREAKER MANUFACTURER	SUITABLE (10,000 AIC)	BRANCH CIRCUIT	BREAKER TYPES
SIEMENS	SINGLE (1-POLE)	TWIN (2-POLE)	DUPLEX QUADPLEX
MURRAY	QP	QT	GFCI
PENTAIR	MP-T	MH-T	MP-GT
EATON CUTTLER HAMMER	BR	BRD	BRD
SCHNEIDER SQUARE D	HOM	HOMT	HOM-GFI
GE	THQL	THQL	THQL-GFI
Maximum Circuit Breaker Current Rating A.	70A.	80A.	50A.

Circuit Breaker Current Rating Not to Exceed:
 80A maximum for Single (one) Pole & Twin (two) Pole TYPE breakers.
 50A maximum for Duplex & Quadplex TYPE breakers (2 circuits per space).
 Maximum continuous load not to exceed 90% of the Ampere rating of any over current device installed.
 *Recommended for use with Pentair IntelliFlo® pumps.

TERMINALS	TORQUE LB.-IN.	RELAY CONTACT OUTPUT
MAIN LUGS L1 & L2	20 - 4 AWG	General: 25A, 277VAC
NEUTRAL & GROUND BAR	50 LB.-IN.	PUMP
14-10 AWG	20 LB.-IN.	1.5 HP 120 VAC
8 AWG	25 LB.-IN.	1.5 KW 120 VAC TUNGSTEN
6 AWG	35 LB.-IN.	3 HP 277 VAC
4 AWG	45 LB.-IN.	20 FLA/120 LRA, 120 VAC
		4.8 KW 240 VAC TUNGSTEN
		17 FLA/102 LRA, 277 VAC
		20A, 277 VAC BALLAST

CAUTION: RISK OF ELECTRIC SHOCK, READ INSTALLATION MANUAL.

IMPORTANT: This Control Panel must be installed in compliance with the National Electrical Code (NFPA 70) including article 680, as well as all local Authority Having Jurisdiction requirements. Mount enclosure with conduit holes down. The Main and Neutral lugs are suitable for 14 AWG to 2/0 AWG conductors. See Table for lug screw tightening torque values. Install only APPROVED circuit breakers. See Table for suitable Listed Circuit Breakers. See Circuit Breaker Case Marking for wire size and torque requirements. This control is not provided with integral GFCI protection for the lighting circuit. When this control is used to power or switch an underwater luminaire, suitable GFCI protection shall be provided in the field. Follow manufacturers' instructions for installing and testing of Ground Fault Circuit Breakers (GFCB) and Interrupters (GFCI); (Canada Class A GFCI). An APPROVED GFCI duplex receptacle may be installed in the rectangular knockout provided on the right side of the enclosure. If the panel is installed outdoors, an APPROVED TYPE 3R (RAINPROOF) Cover MUST be installed over the wiring device in the rectangular opening. Make sure connections inside the low voltage compartment are well insulated, connectors properly seated and wiring lugs tightened. After wiring is completed, install front panel over wiring compartment opening and close off any unused breaker openings with filler plates.

TYPE 3R "Rainproof" (IPX3). Enclosure suitable for INDOOR or OUTDOOR USE.
 Control Panel suitable for SWIMMING POOL/SPA applications.

Electrical Rating: 120/240VAC 150 AMP Single Phase (3 Wire).
 The input line to this control panel should be protected by a 240 VAC circuit breaker rated at NO MORE than 150 Amperes maximum.
 Control Transformer Input: 120VAC, 2A; 240VAC, 1A, 50/60Hz.
 SCG Transformer Input (if equipped): 120VAC, 2.5A; 240VAC, 1.3A, 50/60 Hz.
 Short Circuit Current Rating: 5000 RMS SYMMETRICAL AMPERES.
 Use COPPER CONDUCTORS ONLY. Use 14 AWG to 6 AWG, 60/75°C
 Copper conductors for all field wiring.

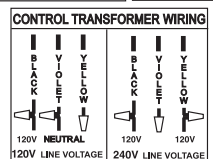

IntelliChlor® SALT CHLORINE GENERATOR OPTION FOR OUTDOOR USE ONLY

TRANSFORMER INPUT:
 120VAC@2.5A, 50/60 Hz
 240VAC@1.3A, 50/60 Hz
 WIRING CONFIGURATION FACTORY SET FOR 240V.

WARNING: DISCONNECT LOAD CENTER POWER BEFORE SERVICING SCG TRANSFORMER
 Connect the Salt chlorinator transformer to the FILTER PUMP RELAY ONLY. The chlorinator should only be powered when the Filter Pump is ON.

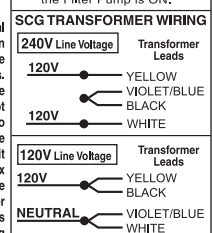

WARNING
 DO NOT USE AN EASYTOUCH® OR INTELLITOUCH® SYSTEM TO CONTROL AN AUTOMATIC POOL COVER. SWIMMERS CAN BECOME ENTRAPPED UNDER THE COVER, WHICH COULD RESULT IN INJURY AND/OR DEATH.

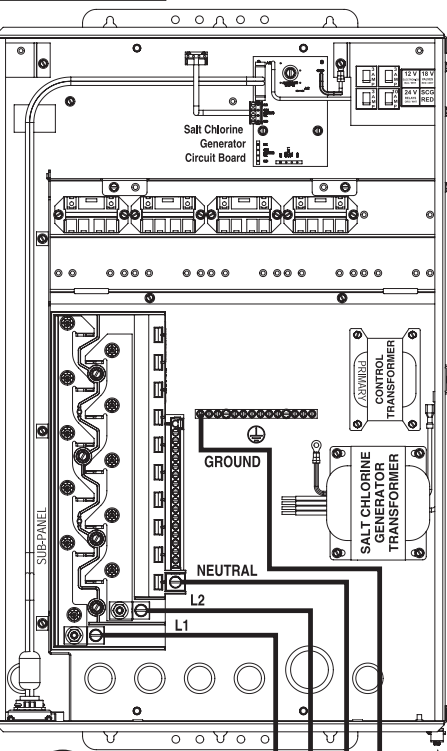

UL LISTED
POOL/SPA CONTROLLER 5K42

EasyTouch System Wiring Diagram

Section 3

IntelliTouch® System Overview

IntelliTouch System Components

The main required components of an IntelliTouch system is a Load Center or Power Center, IntelliTouch Personality Kit, and Interface:

Load or Power Center

- **Load Center:** Provides a larger footprint (26" H x 17" W x 5-1/4" D) Includes built-in sub panel (150 AMPS) capable of holding up to eight 1" breakers. Also includes five 25 AMP three HP relays, 110/240 V transformer with secondary side circuit protection. Multiple knockouts for different sizes of conduit are supplied as well as a GFCI side knockout. The Load Center provides ample space for all high and low voltage wiring needs.
- **Power Center:** Offers a smaller footprint (20" H x 17" W x 5-1/4" D) than the Load Center. The Power Center does not include a circuit breaker base. Users should choose this enclosure if they already have existing circuit breakers/sub-panel for their equipment.

IntelliTouch Personality Kits

There are several types of IntelliTouch control systems available for different pool/spa configurations:

- **Shared Equipment: Pool and spa combinations with shared filtration system** – Pool owners can enjoy the convenience of motorized valves for water flow separation between pool and spa. The Personality Kit models are:
 - **i5+3 (P/N 521219)** – Four auxiliary circuits plus filter pump operation (create a Feature circuit for valve actuators without using an existing output auxiliary circuit, and special light functions for color lighting). Five relays are included in the Load Center.
 - **i7+3 (P/N 521220)** – Six auxiliary circuits plus filter pump operation and the +3 option (create a Feature circuit for valve actuators without using an existing output auxiliary circuit, and special light functions for color lighting). Two relays are included in the kit and five in the Load Center.
 - **i9+3 (P/N 521221)** – Eight auxiliary circuits plus filter pump operation and the +3 option (create a Feature circuit for valve actuators without using an existing output auxiliary circuit, and special light functions for color lighting). Four relays are included in the kit and five in the Load Center.
- **Dual Equipment: Pool and Spa with Dual Sets of Equipment** – The IntelliTouch i10+3D (P/N 521222) is designed to operate two sets of pool equipment. Each set of a equipment (Pool or Spa) can control one temperature setting. This IntelliTouch Personality Kit can control up to 10 pumps and/or lighting circuits, plus two heater circuits. The Personality Kit includes, eight auxiliary circuits plus a filter pump.

The +3 option (create a Feature Macro circuit for valve actuators without using an existing output auxiliary circuit). Five relays are included in the kit and five in the Load Center. You can create a Feature circuit for valve actuators without using an existing output auxiliary circuit, and special light functions for color lighting.

- **Single Equipment: Pool Only or Spa Only Applications** – The IntelliTouch i5S+3 (P/N 521219) and i9+3S provide advanced automation for a single body of water. The i5+3S (P/N 521223) and i9+3S (P/N 521224) Personality Kits includes four auxiliary circuits plus filter pump operation. Five relays are included in the Load Center. The i9+3S Personality Kits includes eight auxiliary circuits plus filter pump operation and the +3 option (create a Feature Macro circuit for valve actuators without using an existing output aux circuit). Four relays are included in the kit and five in the Load Center. You can create a Feature circuit for valve actuators without using an existing output auxiliary circuit, and special light functions for color lighting. This model also allows HI-TEMP and LO-TEMP settings.

IntelliTouch Accessory Power Center Expansion Kits

- **Expansion Kits:** Models i5X (P/N 521225) and i10X (P/N 521226), offer five or ten additional Auxiliary Circuits for systems i9+3, i9+3S and i10+3D. Each IntelliTouch Expansion Kit requires a Load Center (P/N 521213) or Power Center (P/N 521214). Up to three Expansion Kits and Load or Power Centers may be added to a system, for control of up to 38 Auxiliary Circuits (40 auxiliary circuits for i10+3D).

IntelliTouch Personality Kit Contents

The following items are included in the IntelliTouch Personality Kit. If any item is missing or damaged in the IntelliTouch kit, contact your authorized dealer, or contact Pentair Technical Support (page 9).

- An IntelliTouch interface
- Outdoor Control Panel. Includes a motherboard and a Personality circuit board.
- Power Relays - (Models i5+3, i5S+3 no relays, i7+3 Qty. 2, i9+3, i9+3S Qty 4, i10+3D Qty 5, i5x (no relays, i10x (5 relays)
- Valve Actuators - Qty 2 (Models i5+3, i7+3, i9+3)
- Temperature Sensors - Water Sensor (with long cable, including o-ring and hose clamp), Air Sensors (with short cable). For i10+3D only, two Water Sensor (with long cable)
- Wiring Diagram Label for models i5S+3 and i9+3S and i10+3D. For models i5+3, i7+3, i9+3, refer to the Load Center and Power Center inside front door.
- Load Center or Power Center parts bag: Includes relay screws. (see page 2)
- Label Sheet - A set of adhesive labels for custom identification (used to label the outdoor control panel buttons). Use a pair of fine-tip tweezers to remove the labels from the sheet.
- IntelliTouch Personality Kit Installation Guide (P/N 521074)

Note: For information about the IntelliTouch Indoor Control Panel and MobileTouch Wireless Controller, refer to the IntelliTouch System User's Guide (P/N 521075).

Optional Equipment (IntelliChem)

- IntelliChem® no-pump (P/N 521357), one-pump (P/N 521356), two-pump (P/N 521355)
- IntelliChem Installation and User's Guide (P/N 521363)

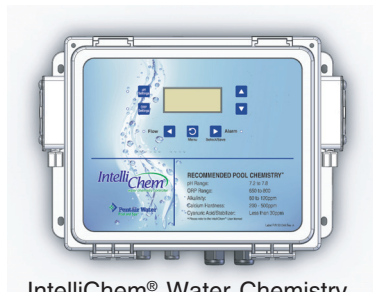

IntelliChem® Water Chemistry Controller (P/N 521356)

IntelliTouch Interfaces

Choose one or more of the following interface options to control pool and spa operations.

- **iPhone™/iPad® Touch Interface (P/N 520500)** – Includes Protocol Interface Adapter that connects to existing Desktop or Laptop PC. This allows control of IntelliTouch or EasyTouch pool and spa systems via PC (requires PC with an Ethernet connection, and Windows® XP operating system).
- **iTC35 Kit (P/N 520502)** – Includes in-wall color touch screen with Ethernet (RJ45) connection and Protocol Interface Adapter and wireless router. The in-wall Touch screen is custom configured for IntelliTouch and EasyTouch systems. Requires an Ethernet cable to router.
- **iTC45 Kit (P/N 520503)** – Includes wireless Tablet with color touch screen, Protocol Interface Adapter, and wireless router. The Tablet is custom configured for IntelliTouch and EasyTouch systems.



iPhone™

(for use with ScreenLogic2™)



In-Wall Touch Screen



Digital Tablet



Indoor Control Panel

- **Indoor Control Panel (P/N 520138)** – 3.75” monochrome backlit LCD control panel. Connects to the IntelliTouch Personality board in the Load Center.
- **MobileTouch® Kit (P/N 520906)** – 3.75” monochrome backlit LCD wireless control panel with Transceiver antenna. Allows any IntelliTouch wired system to also have a wireless remote with all the capabilities of the Indoor Control Panel. With an average range of 300 feet, pool owners have system control anywhere around the home or yard. Powered by a rechargeable lithium-ion battery. Includes a cradle for recharging. The MobileTouch control panel without the Transceiver antenna (P/N 520907) is also available.
- **QuickTouch® II (P/N 521245) and QT4 (P/N 520148) Wireless Remote:** Four-function wireless remote for pool and spa functions of your choice. This controller transmitter operates up to 150 feet range from the Load Center or Power Center.
- **SpaCommand® (P/N 521176) - iS10 (P/N 520149) - iS4 (P/N 520094) :** 10-function (SpaCommand/iS10) and 4-function (iS4) Spa-Side remote controller for pool and spa functions of your choice. The controllers can operate up to 150 feet range from the Load Center or Power Center.

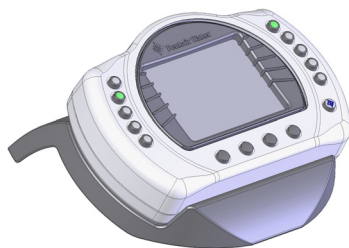

MobileTouch® Wireless Controller



SpaCommand™



QuickTouch® II wireless remote

Optional IntelliTouch Expansion Enclosure

Expansion enclosures can support all of the same high voltage connections as the main load to the Load Center or Power Center. The Expansion enclosure supports the same COM port connections, and includes two actuators as the Load Center or Power Center. The Expansion enclosure can be expanded to include up to five actuators (with valve module P/N 520285). Refer to the IntelliTouch Expansion Kit Installation Guide (P/N 520471) for more information.

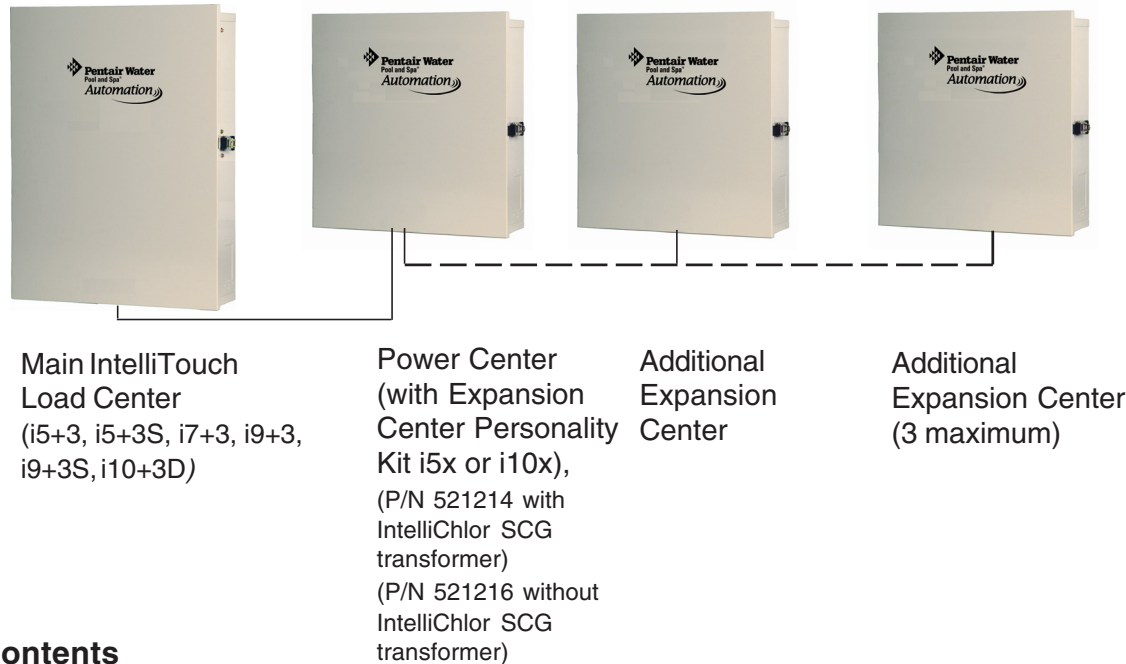

Kit Contents

The following items are included in the Load Center or Power Center kit.

- IntelliTouch® Load Center or Power Center enclosure.
- Relays: (i7+3 (qty. 2), i9+3, i9+3S (qty. 4), i10+3D ((qty. 5)
- Actuators: i5+3, i7+3, i9+3 (qty. 2)
- Temperature Sensor (all models): Water Sensor Long Cable (qty. 1) (o-ring and hose clamp)
Air sensor - Short cable (qty. 1) - i10+3D additional water sensor long cable (qty. 1)
- Wiring Diagram Label - To affix to the inside front door (for models i5S, i9+3S, i10+3D, i5x and i10x). i5, i7+3 and i9+3 not required in kit (see load center door).
- Parts bag: Relay screws (qty. 0, 4, 8, or 10) label sheet
- IntelliTouch Load Center Installation Guide (this manual).
- For additional IntelliTouch installation information, refer to the IntelliTouch Personality Kit Installation Guide (P/N 521074) and the IntelliTouch System User's Guide (P/N 521075).

Affixing the System Wiring Diagram Label (provided in kit) - see page 43)

To affix the wiring diagram label on the enclosure inside front door:

1. Open the enclosure front door.
2. Peel the backing off the wiring diagram label.
3. Position the label in middle of the inside of the front door. Apply even pressure on the surface of the label to secure in place.

System Start-Up

The following information describes basic start-up procedures. For more detailed troubleshooting information, refer to the IntelliTouch Systems User's Guide (P/N 521075). Before you power up the Power/Load Center check the following:

Check Electronics

Check that the following plugs are seated correctly on the Personality board:

- Relay connectors - **FLTR PUMP - AUX1 - AUX10**
- Temperature sensors connectors **WATER, SOLAR, AIR**
- Transformer conductor harness **J2** attached to the Personality board.
- Heater control connector **ELEC HTR** or two-conductor screw terminal.

Refer to Summary Installation Steps (page 5) and Power/Load System Wiring Diagrams, on page 32 and 43.

System Test

The following describes how to test the Outdoor Control Panel to activate the heater, valves and pumps. This test assumes that all system equipment has been properly installed and connected to the Power/Load Center.

Testing Valve Actuators and Pumps

Use the following steps to test the valve actuators (CVA24T) for proper rotation. For Outdoor Control Panel System i5+3, i7+3, i9+3 (shared equipment).

To test the valve actuators and pump:

1. Power up the Power/Load Center.
2. Press the **SYSTEM CONTROL** button on the Outdoor Control Panel until the **SERVICE** light is on.
3. Press the **V (Valve)** button to select **POOL**.
4. Press the **F (Filter Pump)** button to activate the filter pump. Water will be removed from the pool and returned to the pool.
5. Set both valve actuators (CVA-24T) for suction and return. Use the toggle switch on the rear of the CVA-24 to withdraw and return water from the pool.

Note: With the filter pump operating, if the water is not being removed and returned to the pool, it may be necessary to reverse the **RETURN** with **VLV A** (or **VLV B**) plugs on the Personality board.

Testing the auxiliary relays

Affix the auxiliary relay labels to the appropriate buttons on the Outdoor Control Panel. If necessary, write the function on the control panel.

- Toggle the filter pump, each auxiliary circuit, heater and solar and verify the function. Press the **SYSTEM CONTROL** button to set the system in "**AUTO**" mode when done.

Solar System Installation

- To ensure maximum flow of water through the solar panels, a solar booster pump should be added if panels are installed at a very high elevation.
- It is recommended that the solar panels are mounted in a way that gravity will allow draining whenever the filter pump is not on.
- For systems with glazed panels, damage can occur from overheating if the filter pump is still running after the solar has turned off. To enable glazed panels to automatically drain whenever the solar turns off (even if the filter pump is still running), a 1/2" motorized solar drain valve should be plumbed from the solar feed line, through a check valve, to a zero psi point (such as pool fill line or jet air intake).

Solar System Start-Up

1. Switch power on to the IntelliTouch Load Center.
2. If pool cleaner protection has been added to the system, the pool cleaner pump motor should be activated whenever the pool cleaner timer is on. Momentarily turn pool cleaner on and off to check the motor is operating correctly.
3. Check that Solar Valve is in "solar bypass" position, diverting water away from solar panels. If Solar Valve is staged incorrectly (diverting water to the solar panels), reverse switch on back of Valve Actuator (change from ON1 to ON2, or vice-versa). The Valve Actuator will automatically rotate to the correct position.
4. Check that Solar Valve has rotated from the "solar bypass" position to the "solar" position, diverting water through the solar panels.
5. The system is now ready to be operated as desired.

Pool Cleaner Protection

Recommended for use in pool systems which utilize a "booster pump" pool cleaner. This feature automatically turns off the pool cleaner pump for a few minutes whenever solar is initiated. This will protect the pump from damage caused by air in the solar panels at system start-up.

Installing the IntelliTouch Outdoor Control Panel

WARNING BEFORE INSTALLING THE LOAD CENTER AND POWER CENTER, ALWAYS SWITCH OFF THE MAIN POWER into the home at the main circuit breaker box.

The IntelliTouch Outdoor Control Panel includes a main circuit board and the Personality circuit board. The Personality board is mounted on top of the main circuit board which mounts on the back of the Outdoor Control Panel. The control panel installs in the top part of the Power/Load Center enclosure. The Power/Load Center receives control inputs from the Personality board and distributes high voltage power to Pentair Valve Actuators (PVA), control pumps, lights, and heater operations. The IntelliTouch remote Indoor Control Panel also controls these and other functions, such as pool and spa lights.

To install the Outdoor Control Panel:

1. Unlatch the front door spring latch and open the front door of the Load Center.
2. Remove the two (2) retaining screws securing the high voltage cover-panel. Remove the HIGH VOLTAGE COVER PANEL from the enclosure.
3. Remove the Outdoor Control Panel from the Personality Kit and its packaging.
4. Mount the Outdoor Control Panel in the top part of the Load Center. Secure the lower edge of the control panel with the two retaining screws. Once secured, the Control Panel can hinge out and down to access the Personality board for low voltage connections.
5. When finished with the low voltage connections on the Personality board, close the hinged control panel and secure it with the two access screws.
6. Install the cover-panel and secure it with the two screws.
7. Close the front door of the Load Center. Fasten the two spring latch.

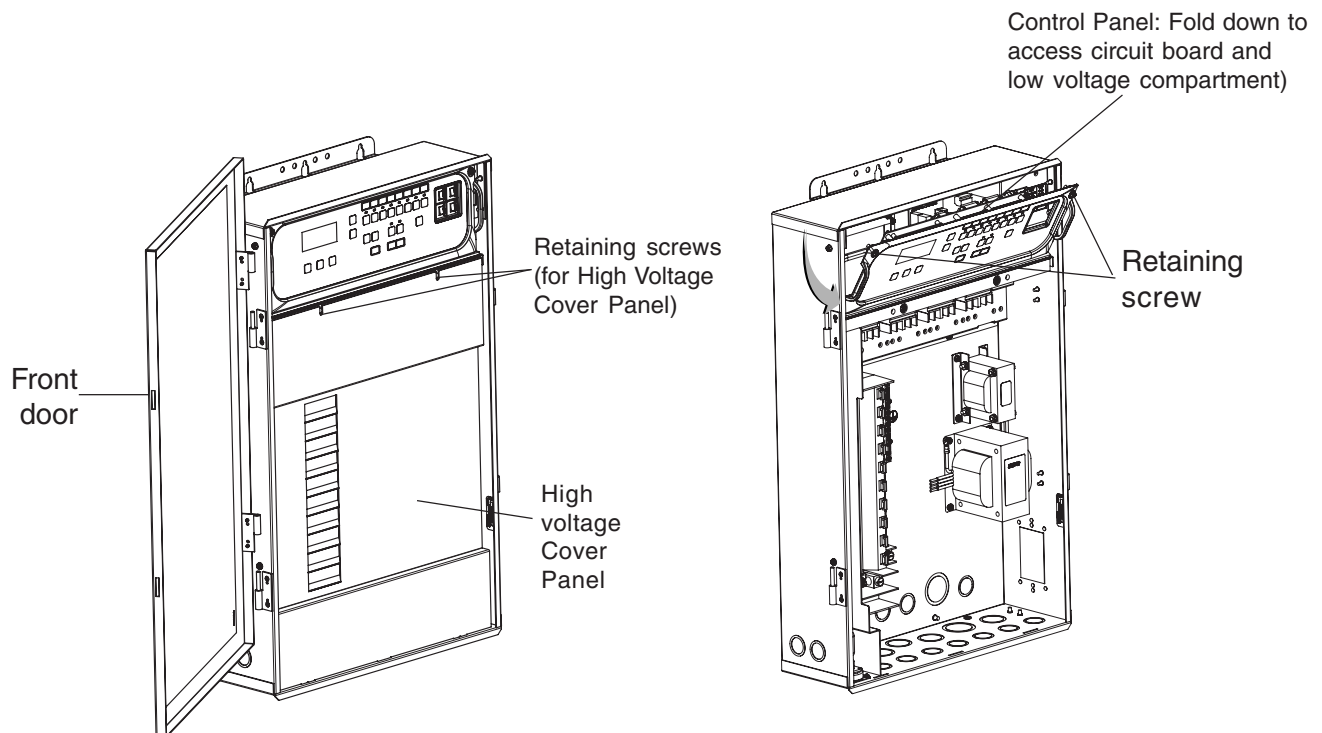

Load Center (front view)
(front door and high voltage compartment panel removed)

IntelliTouch Outdoor Control Panels

For IntelliTouch system wiring diagrams, see pages 41-43.

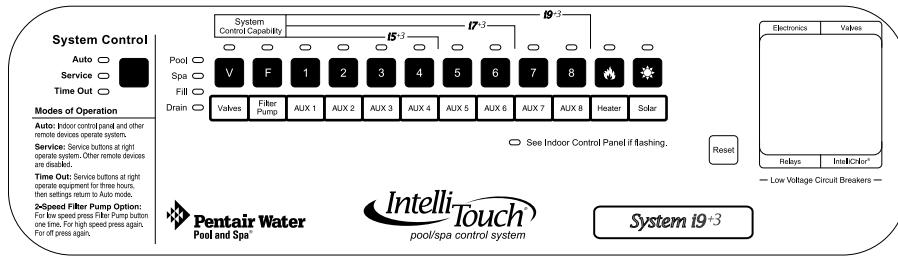

Shared Equipment Systems Model i5+3, i7+3, i9+3

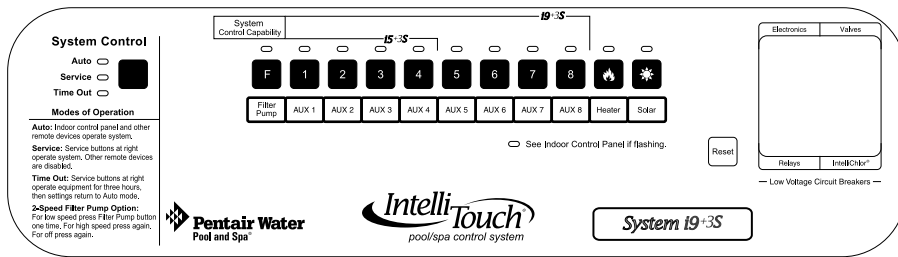

Single Body Systems Model i5+3S, i9+3S

Operates the same as i5+3, i9+3, except no valve controls.

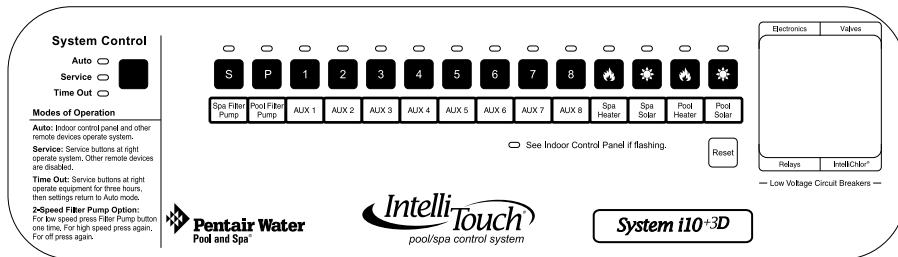

Dual Body Dual Equipment System Model i10+3D

The i10+3D is designed to operate two sets of pool equipment. Each set of a equipment (Pool or Spa) can control one temperature setting. Operation same as i9+3 except **S** and **P** buttons operate independent filter pumps and the Heater and Solar buttons operate independent heating systems and no valve controls.

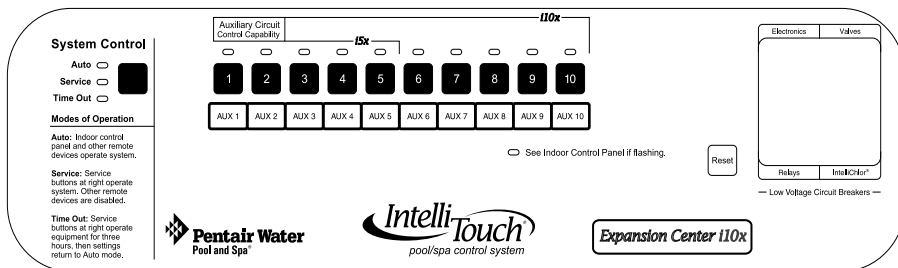

Expansion Centers Model i5x, i10x

Expansion Centers provide additional valve and auxiliary circuits. They are designed to operate with base systems: i9+3, i9+3S, i10+3D. The “Auxiliary circuit control capability” buttons operate the same way as on the main base Outdoor Control Panel.

IntelliTouch System Wiring Diagram (i10+3D, i5+3S and i9+3S)

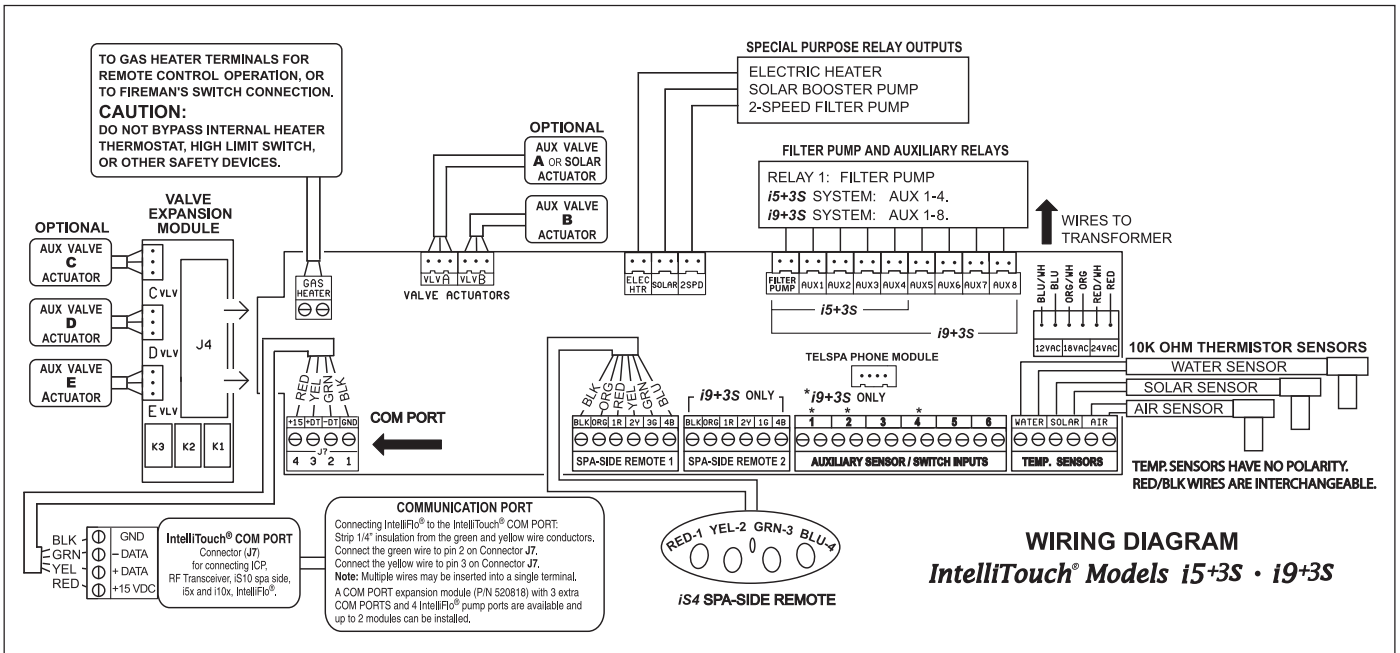
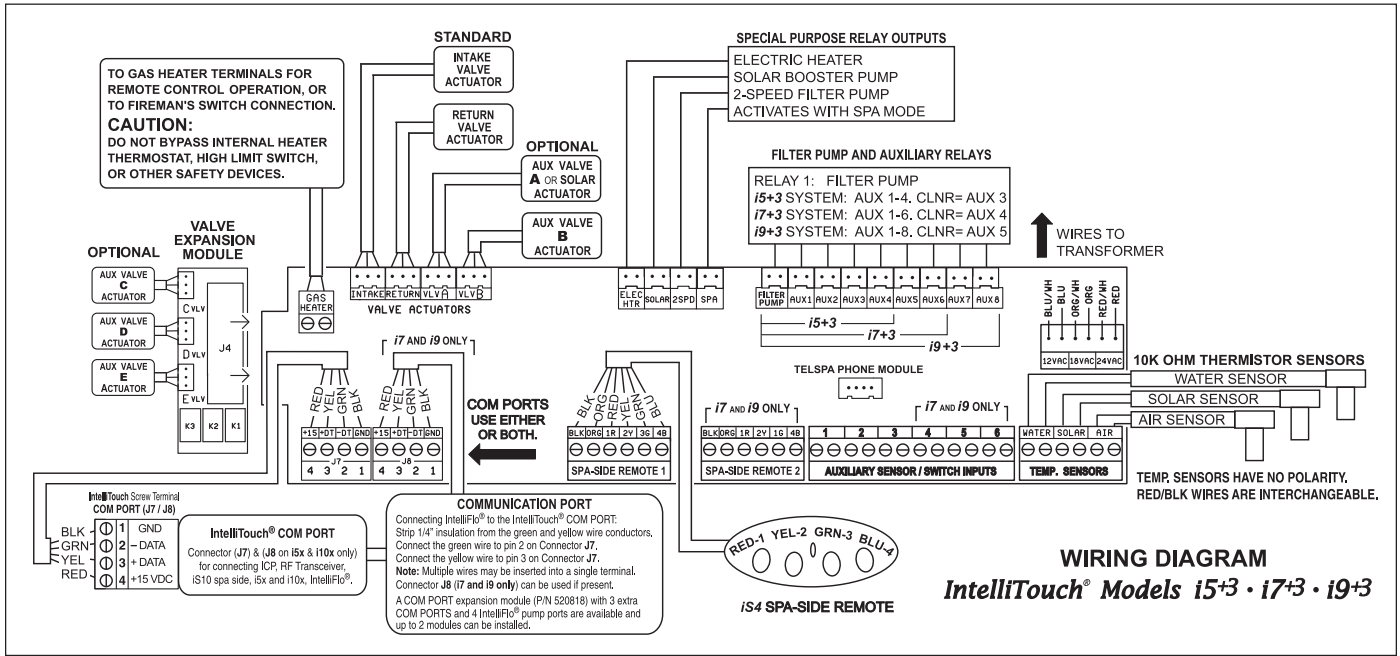

IntelliTouch System Wiring Diagram (i10x and i5x)

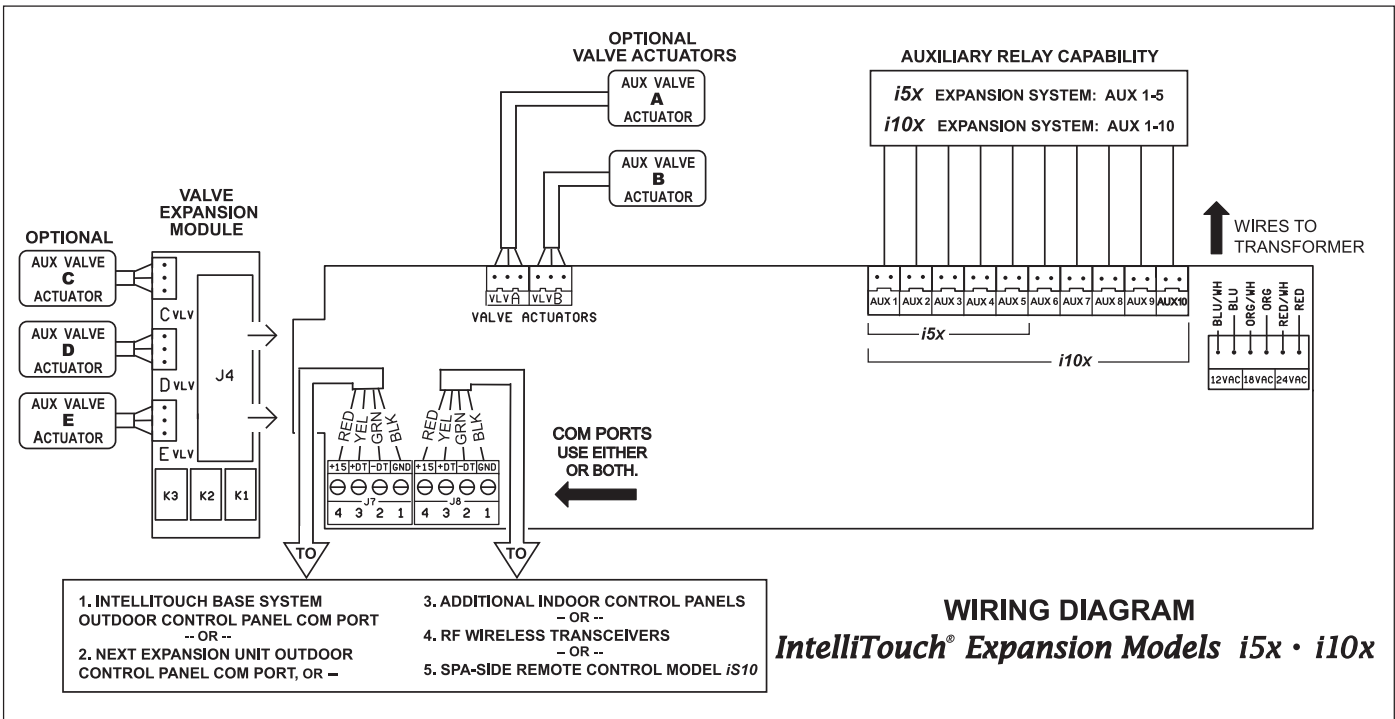
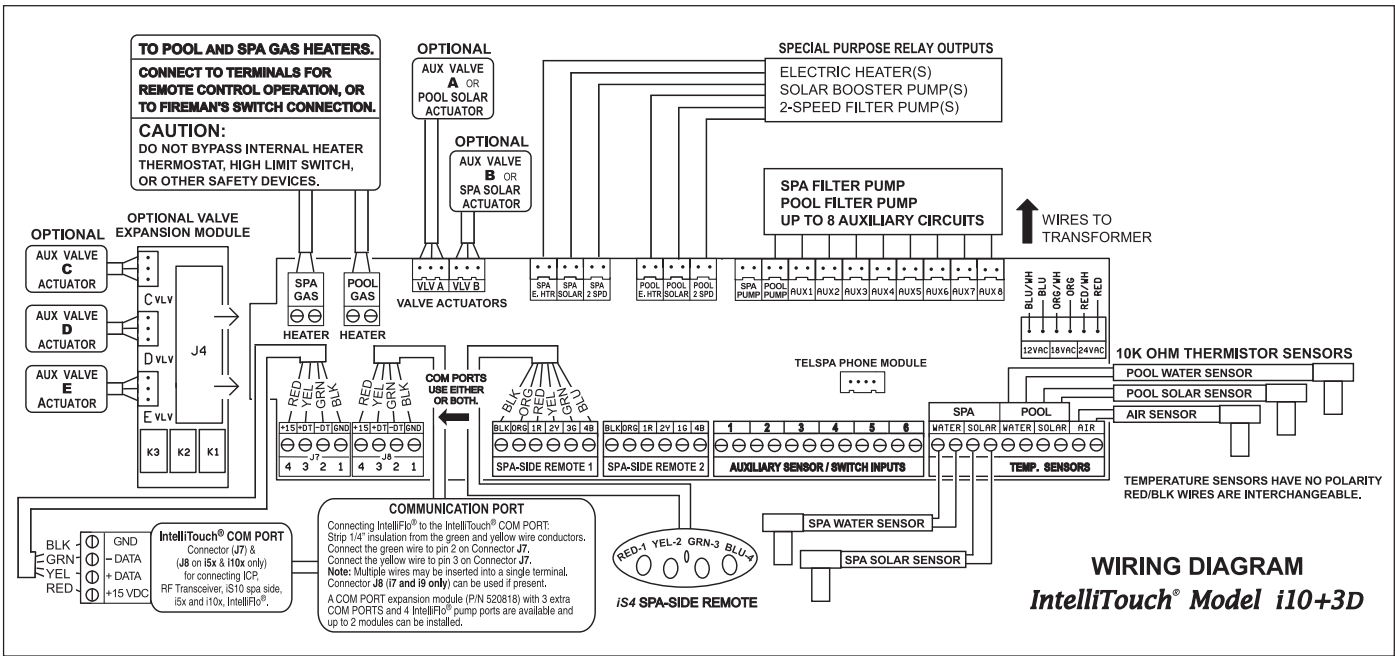

WARNING PREVENT ELECTROCUTION DISCONNECT ALL SUPPLY CONNECTIONS BEFORE SERVICING. THIS APPLIANCE MAY HAVE UP TO 11 SUPPLY CONNECTIONS.

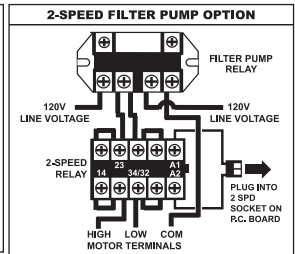
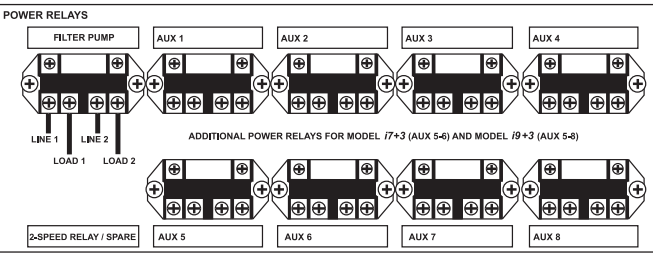
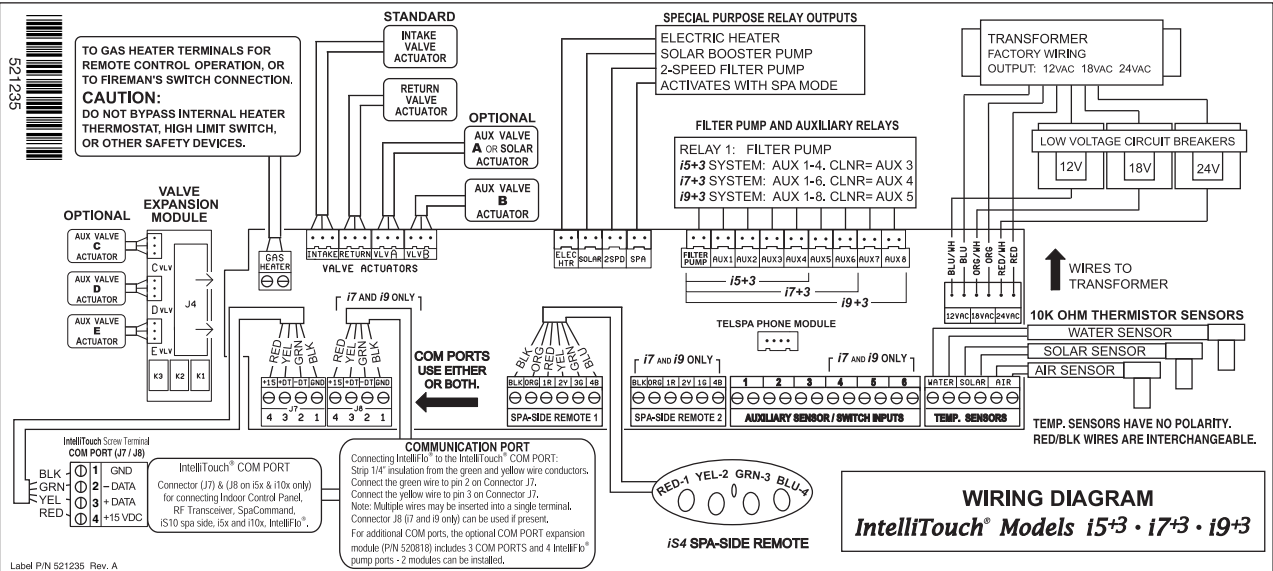

PREVENT WATER DAMAGE
KEEP DOOR CLOSED

A disconnecting means must be located within sight from the equipment and at least 5 feet (1.52 m) from the inside walls of the pool, spa or hot tub.

CAUTION: RISK OF ELECTRIC SHOCK, READ INSTALLATION MANUAL.
IMPORTANT: This Control Panel must be installed in compliance with the National Electrical Code (NFPA 70) including article 680, as well as all local Authority Having Jurisdiction requirements. Mount enclosure with conduit holes down. This control is not provided with integral GFCI protection for the lighting circuit. When this control is used to power or switch an underwater luminaire, suitable GFCI protection shall be provided in the field. Follow manufacturers' instructions for installing and testing of Ground Fault Circuit Breakers (GFCB) and Interrupters (GFCI); (Canada Class A GFCI). An APPROVED GFCI duplex receptacle may be installed in the rectangular knockout provided on the right side of the enclosure. If the panel is installed outdoors, an APPROVED TYPE 3R (RAINPROOF) Cover MUST be installed over the wiring device in the rectangular opening. Make sure connections inside the low voltage compartment are well insulated, connectors properly seated and wiring lugs tightened. After wiring is completed, install front panel over wiring compartment opening.

WARNING
 DO NOT USE AN EASYTOUCH® OR INTELLITOUCH® SYSTEM TO CONTROL AN AUTOMATIC POOL COVER. SWIMMERS CAN BECOME ENTRAPPED UNDER THE COVER, WHICH COULD RESULT IN INJURY AND/OR DEATH.

TYPE 3R "Rainproof" (IPX3). Enclosure suitable for INDOOR or OUTDOOR USE. Control Panel suitable for SWIMMING POOL/SPA applications. Electrical Rating: 120/240VAC 150 AMP Single Phase (3 Wire). The input line to this control panel should be protected by a 240VAC circuit breaker rated at NO MORE than 150 Amperes maximum. Control Transformer Input: 120VAC, 2A; 240VAC, 1A, 50/60Hz. SCG Transformer Input (if equipped): 120VAC, 2.5A; 240 VAC, 1.3A, 50/60 Hz. Short Circuit Current Rating: 5000 RMS SYMMETRICAL AMPERES. Use COPPER CONDUCTORS ONLY. Use 14 AWG to 6 AWG, 60/75°C Copper conductors for all field wiring.

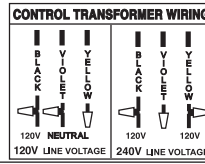

RELAY CONTACT OUTPUT	
General: 25A, 277VAC	
PUMP	LIGHT
1.5 HP 120 VAC	1.5 KW 120 VAC TUNGSTEN
3 HP 277 VAC	4.8 KW 240 VAC TUNGSTEN
20 FLA/120 LRA, 120 VAC	20A, 277 VAC BALLAST
17 FLA/102 LRA, 277 VAC	

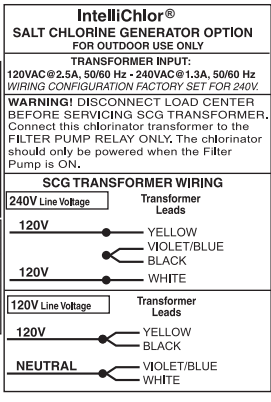

Sanford NC • Moorpark CA

Customer Service 800-831-7133

Plumbing Requirements

It is important that the pool and spa plumbing system be in accordance with local codes and the Recommended Hydraulic Schematics (page 45 and 46). Before starting, please review the diagrams and the following recommended guidelines:

- 1 The spa should be at or above the level of the pool.

If the spa is attached to the pool, provide a dam between the two bodies of water to allow the spa to overflow into the pool. If the spa is not attached to the pool, an overflow, sufficient in size to carry a full pump-flow, must be installed at the water level in the spa.

- 2 Plumb a three-port **Intake Valve** on the suction-side of the filter pump, so that the center port of the valve is connected to the pump inlet. Connect the spa suction to one side of the Intake Valve, and the pool suction to the other side.

- 3 Plumb a three-port **Return Valve** on the return-side of the heater, so that the return water will enter the valve through the center port.

Connect the spa return to one side of Return Valve, and the pool return to the other side.

- 4 If required, install a spa makeup line (consisting of a manual gate or ball valve, for elevated spas install a check valve) to bypass the pool return line. This will enable some of the chemically-balanced water from the pool to cycle through the spa. The manual valve will allow the amount of bypass to be adjusted.

- 5 If the spa is to be constructed in concrete, special provision should be made at this time for the installation of the Spa-Side remote control.

Select a convenient location in the deck or above water level in the spa wall (where the Spa-Side remote will not be submerged by the spa water), and install a 6 in to 12 in length of one inch PVC pipe to provide a receptacle for the Spa-Side remote. The pipe should be level and protrude beyond the finished surface of the spa. It will be cut back later at installation time. Reduce the pipe size down to ½ in or ¾ in conduit, and run it to the proposed Load/Power Center location at the equipment pad. Use sweep elbows for turns.

The Spa-Side remote will not be installed until the spa construction is completed.

- 6 For systems which incorporate a skimmer, it is possible to balance the amount of suction between the skimmer and main drain for maintenance purposes. This is easily accomplished by installing a manual three-port mixing valve at the suction line. Plumb one port to the skimmer and the other to the main drain.
- 7 If a “non-booster pump” pressure-side pool cleaner is being used, plumb a manual three-port valve between the filter pump and filter, with the third port plumbed to the pool cleaner line, and install a motorized two-port **Pool Cleaner Valve** at this line. The motorized valve will automatically open whenever the Control System activates the pool cleaner.
- 8 If a booster pump pool cleaner is being used, plumb the booster pump so that its suction-side is connected to the pool return, after the heater, and as close to the ground as practical.

- 9 Plumb the solar feed and return lines between the filter and the heater. Install a three-port valve at the feed line. Use a solar valve (model SOL-2T), to allow automatic draining of the panels.
- 10 A solar booster pump should be used when the distance to the panels exceed 200 ft., or the panels are elevated higher than 25 ft.
- 11 Glazed solar panels require a drain valve (model HW-5B) to allow draining of the panels. This prevents damage from overheating water. Install a drain valve at the solar feed line and connect to the pool fill line.
- 12 **SCG systems only:** IntelliChlor IC40 or IC20 salt chlorine generator (SCG) cell with check valve at the heater output. Refer to IntelliChlor User's Guide (P/N 520589) for plumbing requirements.

Equipment Location

All equipment, with the exception of the spa-side remote, must be located at least 10 ft. from the water's edge.

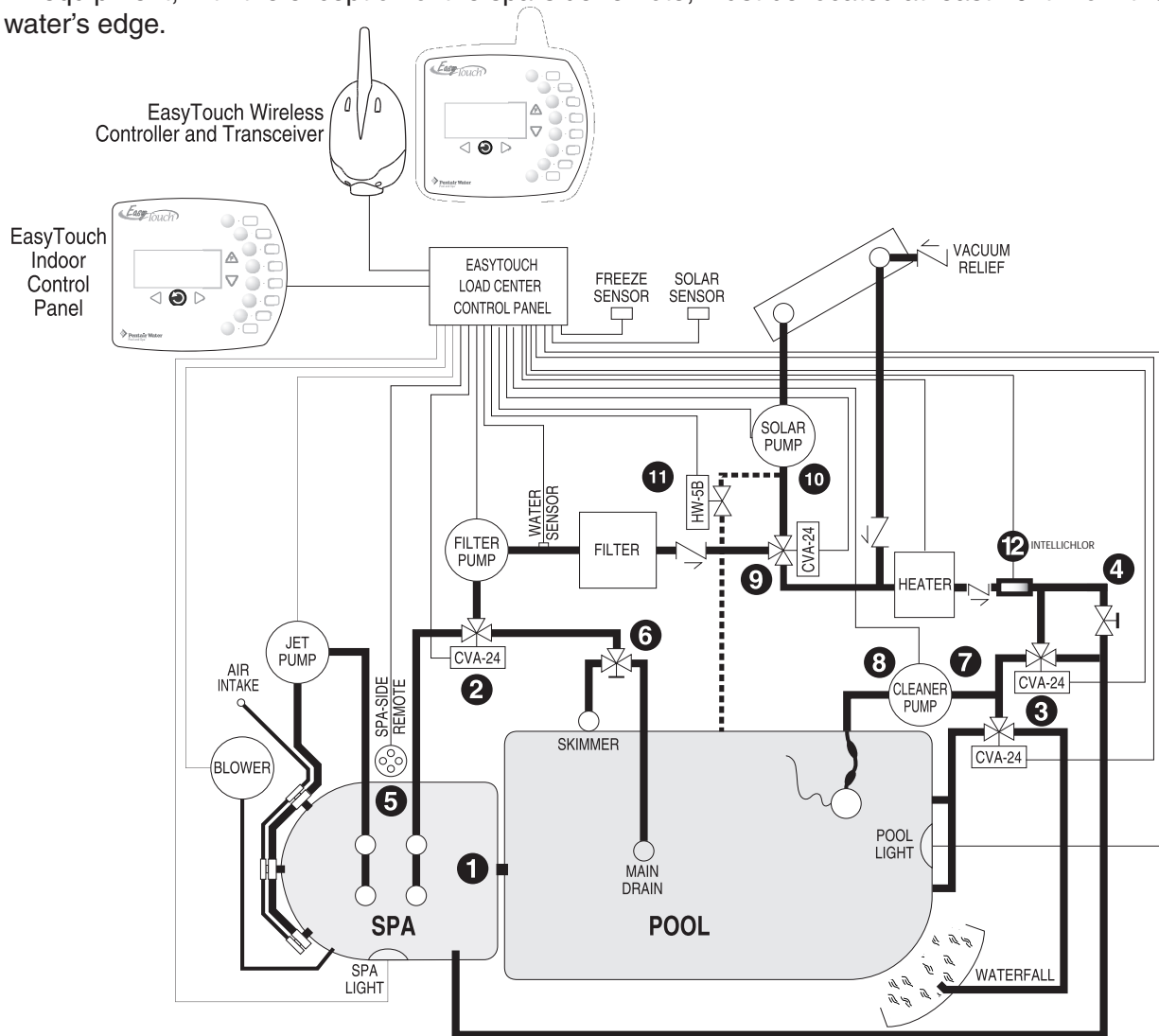

Recommended Hydraulic Schematic for Shared Equipment System

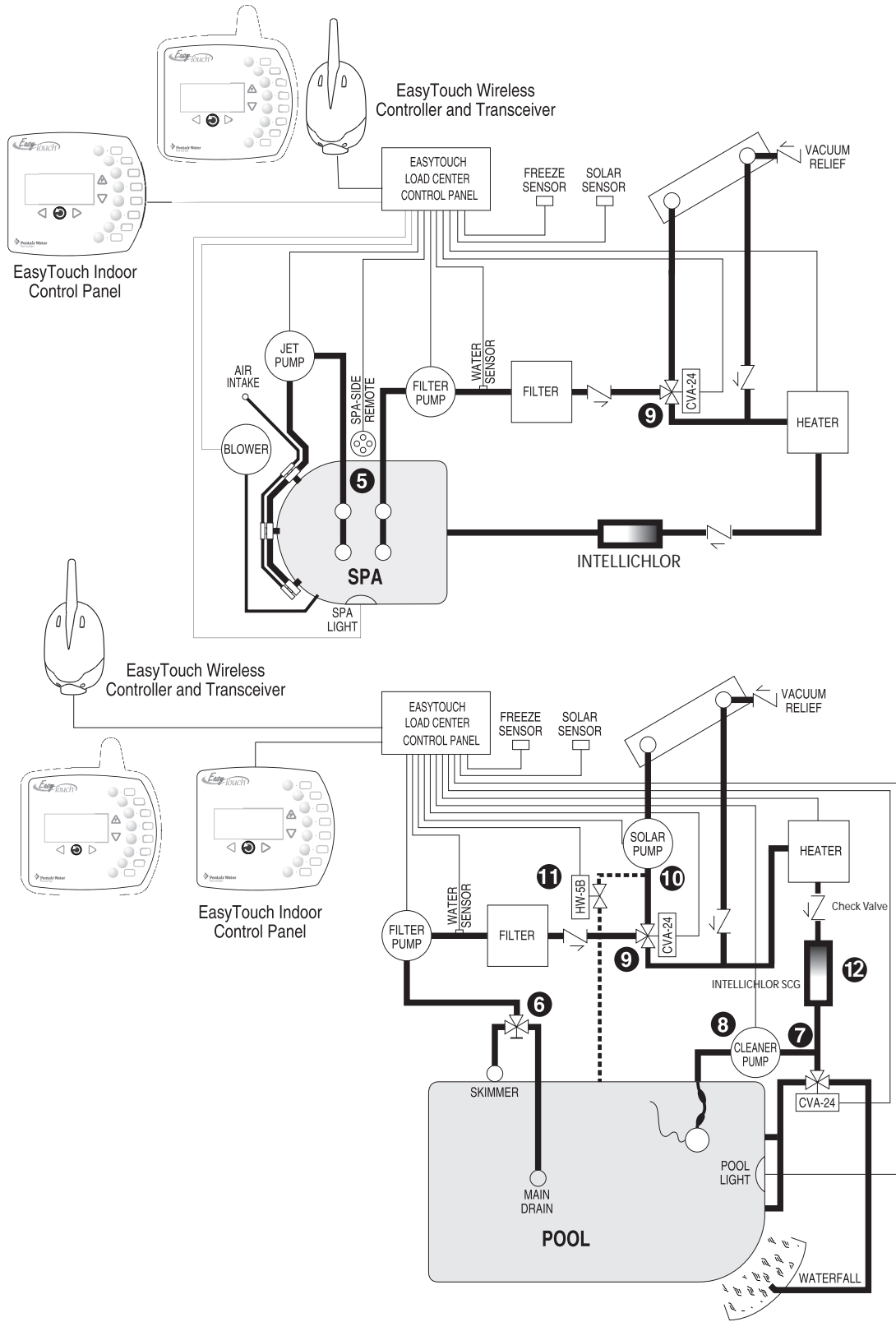

Recommended Hydraulic Schematic for Single Body System

Glossary

Control Panel: The EasyTouch control panel with flexible hinge. Installed in upper portion of EasyTouch load center to control the EasyTouch pool and spa system.

EMI (Electromagnetic interference) filter: Protective circuit element that must be used between the IntelliChlor transformer and supply lines.

High Voltage Panel/Compartment: Removable panel for the high voltage compartment of EasyTouch load center. The high voltage wiring including circuit breakers, relays, GFCI and optional IntelliChlor transformer/filter.

Indoor Control Panel: This 9 or 13 button remote controller with LCD (liquid crystal display) is wired to the control circuit board in the EasyTouch load center. The control panel can be wall mounted inside a house to control the EasyTouch system.

IntelliChlor: Electronic salt chlorinator. Uses a process known as electrolysis to produce sodium hypochlorite (liquid chlorine) from a low concentration of salt added to the pool water. Model IC 20 Cell (P/N 520554) for pools up to 20,000 U.S. gallons (75 liters) and model IC 40 Cell (P/N 520555) for pools up to 40,000 U.S. gallons (151 liters).

iS4: Four function spa-side remote. Spa wall or deck mounted.

Load Center: Metal enclosure with power relays, transformer, and circuit breakers. Used for distributing power for controlling EasyTouch Systems. Also known as the “sub-panel.”

Low Voltage Compartment: Top compartment of EasyTouch load center for all low voltage wiring.

Low Voltage Raceway: Vertical space in the left side of EasyTouch load center for low voltage cabling.

Motherboard: The circuit board mounted behind the EasyTouch control panel.

Relay Circuits: The circuits that control the relays on the motherboard. Connectors on top edge of the circuit board.

Screw Terminal Connector: Removable connector that may attach to circuit board with multiple sockets (anywhere from 2 to 6) to receive conductors from controllers and sensors; conductors held by screw terminals; multiple conductors of a small enough gauge (usually 22 AWG) may be coupled to a single socket of a terminal connector.

Salt Chlorine Generator (SCG): Automated pool chlorinator that sanitizes using salt water (see IntelliChlor).

SpaCommand: Up to ten function spa-side remote with temperature changing capability. Can be spa wall or deck mounted.

Transceiver: Used by the EasyTouch wireless control panel. Circuit board with attached antenna that can send and receive radio frequency (wireless) transmissions.

Glossary

Expansion Kit (IntelliTouch): A kit that includes additional auxiliaries to an existing Personality Kit. Requires a Load Center for each Expansion Kit Power Center.

Feature Circuits: Programmable circuits that may control relays and/or valve actuators. For details, see the IntelliTouch Systems User's Guide (P/N 521075)

High Voltage Compartment: Large lower right compartment of Load Center for all high voltage wiring including circuit breakers, relays, and GFCI.

Indoor Control Panel: This EasyTouch or IntelliTouch remote controller with LCD (liquid crystal display) is wired to the Personality board (IntelliTouch) or Motherboard (EasyTouch) in the Power/Load Center. The control panel can be wall mounted inside a house to control IntelliTouch or EasyTouch systems.

SpaCommand: Up to ten function spa-side remote with temperature changing capability. Can be spa wall or deck mounted.

Load Center: Metal enclosure with power relays, transformer, and circuit breakers. The Load Center is installed prior to Personality Kit installation (IntelliTouch only). Used for distributing power for controlling IntelliTouch or EasyTouch systems. Also known as the "sub-panel."

Low Voltage Compartment: Top compartment of Load Center for all low voltage wiring.

Low Voltage Raceway: Vertical space in the left side of Power/Load Center for low voltage cabling.

MobileTouch Controller (IntelliTouch): Wireless controller for the IntelliTouch Systems with all the functionality of the Indoor Control Panel.

Mud Box: Enclosure to provide mounting features for SpaCommand or iS10 spa-side remote that is cast into gunite, concrete, or other spa wall/deck construction.

Outdoor Control Panel: Control panel with flexible hinge installed in upper portion of Power/Load Center to control IntelliTouch systems.

Personality Board (IntelliTouch): The circuit board mounted on top of the Outdoor Control Panel motherboard. The Personality board defines the system capabilities.

Personality Kit (IntelliTouch): Set of parts to define the capability of a system; may include: Outdoor Control Panel, temperature sensors, actuators, control panel (Indoor or MobileTouch), additional relays, actuators.

Power Center: Same as Load Center with the exception of the circuit breaker base.

Relay Circuits: The circuits that control the relays on the Personality Board (IntelliTouch) or Motherboard (EasyTouch). Connectors on top edge of the circuit board.

Screw Terminal Connector: Removable connector that may attach to circuit board with multiple sockets (anywhere from 2 to 12) to receive conductors from controllers and sensors; conductors held by screw terminals; multiple conductors of a small enough gauge (usually 22 AWG) may be coupled to a single socket of a terminal connector.

Transceiver: Circuit board with attached antenna that can send and receive radio frequency (wireless) transmissions. Used with wireless controllers.

Notes

Notes



P/N 521139 - Rev A