

# WPC2-XXXX-T

Rated for use on 110/120VAC 60Hz and 220/240VAC 60Hz applications

**Installation Instructions: Read these instructions in their entirety before performing any installation work.**

FOR USE WITH POOL AND SPA PRODUCTS

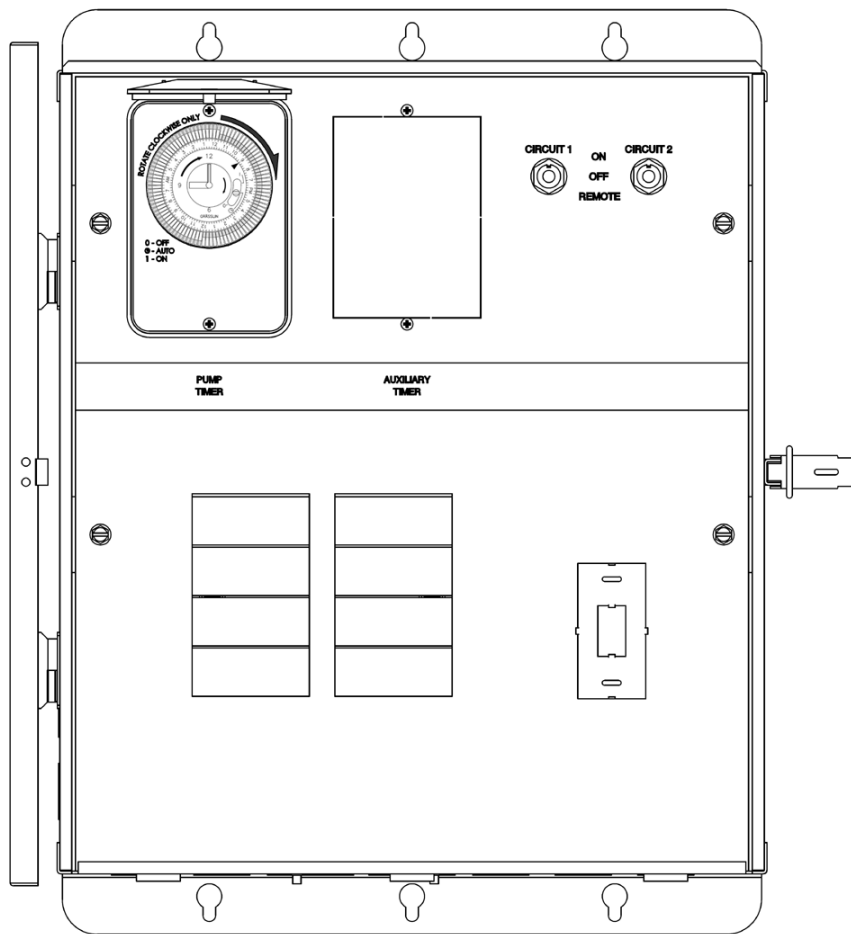

ETL LISTED  
Conforms to UL STD 508;  
Certified to CSA STD  
C22.2 No. 14



The WPC2 single speed version consists of the following parts:

Item	Qty.	Component part No.	Description
1	1	72-15212-00	WPC2 XXXX-T Enclosure
2	1	94-15089-00	WPC-2 Enclosure Door
3	1	37-15000-00	Relay
4	1	41-15004-08	8 Position Terminal Block
5	1	42-15032-00	Timer
6	1	02-15269-00	Load Center Cover Plate
7	2	02-15267-00	WPC-2 Mounting Bracket
8	1	41-15003-00	Grounding Bar
9	1	94-15090-00	WPC Receiver
10	8	10-15086-04	Load Center Cover Plate, Switch Bracket, and Mounting Bracket Screws
11	2	10-15089-06	Terminal Block Mounting Screw
12	2	10-15060-01	Relay Mounting Screw
13	8	10-15089-03	Timer and Receiver Mounting Screws
14	2	A11526	3-Position Toggle Switch
15	1	94-15092-00	WPC Repeater
16	2	10-15089-02	Freeze Device Mounting Screw (Optional equipment)
17	1	20-15013-00	Strain Relief
18	1	02-15270-00	Switch Bracket
19	1	17-15005-00	Latch
20	2	10-15089-01	Latch Mounting Screws
21	1	44-15037-00	Transformer, 12V
22	2	A10670	Transformer Mounting Screws
23	2	11-15022-00	Hex Nuts, Kep

**Accessory Items:**

FP 1/2	Temperature Freeze Device
WE-65	65 ft Repeater Cord Extension Kit
WPC-2/3 ST	GFCI Mounting Kit
DL-HUB	Direct Light Hub Connection Kit
TC-2	Additional Timeclock/Dust Cover

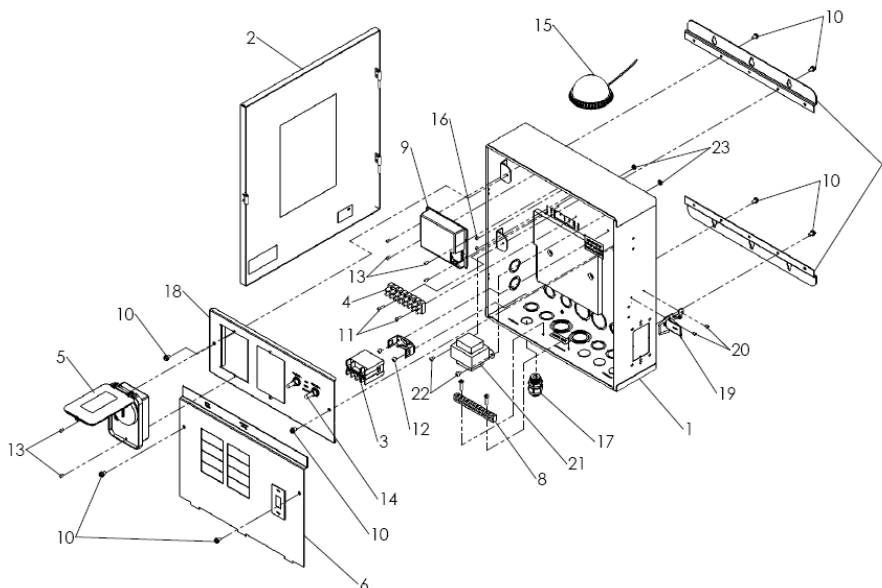



SAVE THESE INSTRUCTIONS!

## IMPORTANT SAFETY INFORMATION

Basic safety precautions should be observed when operating the WPC-2 product and other associated equipment.

1. A qualified electrician must install the WPC-2 in accordance to the National and Local Electrical Codes.
2. The WPC-2 must not be less than 5 feet (3 meters in Canada) from inside edge of pool. **ONLY USE COPPER CONDUCTORS.**
3. Do not exceed the maximum ratings of individual components, wiring devices, and current carrying capacity of conductors.
4. For the bonding, grounding, installing, and wiring of underwater lights to the WPC-2, refer to Article 680 of the National Electrical Code or Article 68 of the Canadian Electrical Code.
5. This device should never operate equipment that could cause property damage, bodily injury, or death should it be activated unexpectedly.
6. Never allow children to operate the WPC-2 unsupervised.

## FCC WARNING

1. This device complies with Part 15 of the FCC Rules. Operation is subject to the following two conditions: (1) this device may not cause harmful interference, and (2) this device must accept any interference received, including interference that may cause undesired operation.
2. Changes or modifications not expressly approved by Fiberstars Inc. could void the user's authority to operate the equipment.

## ELECTRICAL RATINGS

Do not exceed the maximum electrical ratings of the WPC-2. A circuit breaker rated at 20Amps at 120VAC must be installed in the breaker panel to connect to the WPC-2 power input. Circuit 1 is rated for use of up to 2.5 amps @ 12VAC, and Circuit 2 is rated for use of up to 8Amps @ 120VAC. The Pump Relay is rated at a maximum of 3HP @ 240VAC.

SUITABLE LISTED BREAKERS						
MANUFACTURER	CIRCUIT BREAKER					FILLER PLATE
	SINGLE	DOUBLE	TWIN	QUAD	GFCB	
Thomas & Betts	TB	TB	TBBD	TBBQ	GFB	FP-1C-TB
Cutler-Hammer	BR	BR	BRD	BRD	GFCB	BRFP
Square D	HOM	HOM	HOMT	HOMT	HOM-GFI	HOMFP
Murray	MP-T	MP-T	MHT	MHT	MP-GT	LX100FP
Siemens/ITE	QP	QP	QT	QT	QPF	QF-3
Challenger	C	-	A-CT	-	HAGF	#FC-1C
Westinghouse or Bryant	BR	-	BQ	-	GFCB	FP-1
Crouse Hinds	MP	-	TRIPLEX	-	MP-GF	-
GE Regular	THOP	-	-	-	THOP-GF	TQLFP-1

Wiring Information - Copper Conductors Only							
Wire Size 75°C min. Insulation	Supply Circuit Breaker Rating	Terminal Torque*		Max Motor Load (Continuous Duty)		General Purpose Branch Circuit Breaker Rating	General Purpose Branch Circuit Maximum Current Capacity
		Line and Neutral Main Lugs	Neutral and Ground	120V	240V		
		LB-IN	LB-IN	HP	HP		
14	15	35	20	1/2	1	15	12
12	20	35	20	1	2	20	16
10	30	35	20	1 1/2	3	30	24
8	50	40	25	2	5	40	32
6	65	45	35	-	-	60	44
4	85	45	35	-	-	-	-
3	100	50	-	-	-	-	-
2	100/125	50	-	-	-	-	-

## WARNING

- TURN OFF INCOMING POWER BEFORE SERVICING EQUIPMENT.
- ALL INSTALLATION AND MAINTENANCE WORK MUST BE PERFORMED BY QUALIFIED ELECTRICAL PERSONEL ONLY.
- VERIFY ALL ELECTRICAL RATINGS BEFORE INSTALLATION IS COMPLETE.

## LOCATION

Install the WPC-2 enclosure using the mounting plates included with each enclosure. The WPC-2 is housed in a Type 3R rainproof enclosure and can be mounted anywhere between the pool equipment and the breaker panel.

# WIRING INSTRUCTIONS

FOLLOW PROPER WIRING PRACTICES IN ACCORDANCE WITH ALL LOCAL REGULATORY REQUIREMENTS.

### Power Connections:

To wire the WPC-2 use insulated COPPER wire only, 12 gauge minimum. Run a ½” to ¾” conduit from the main breaker panel to the WPC-2. Pull appropriate wires from the main breaker panel to the WPC-2 unit. To make power connections remove 3/8 inches of insulation from wire ends. Connect bare wires to the Load Center as illustrated. Tighten terminal screws firmly (20 lb-in minimum). Connect the common to the Neutral bar (tighten to 20 lb-in minimum). Install a 20 Amp circuit breaker and wire to the 120V LINE and the T/C POWER of the terminal block. Wire the Neutral and T/C NEUTRAL terminals to the Neutral bar on the Load Center. For use with an internal GFCI, punch out the GFCI knockout on the Load Center Cover Plate of the WPC. Install a GFCI with appropriate hardware (sold separately from Fiberstars, part number WPC-2/3 ST).

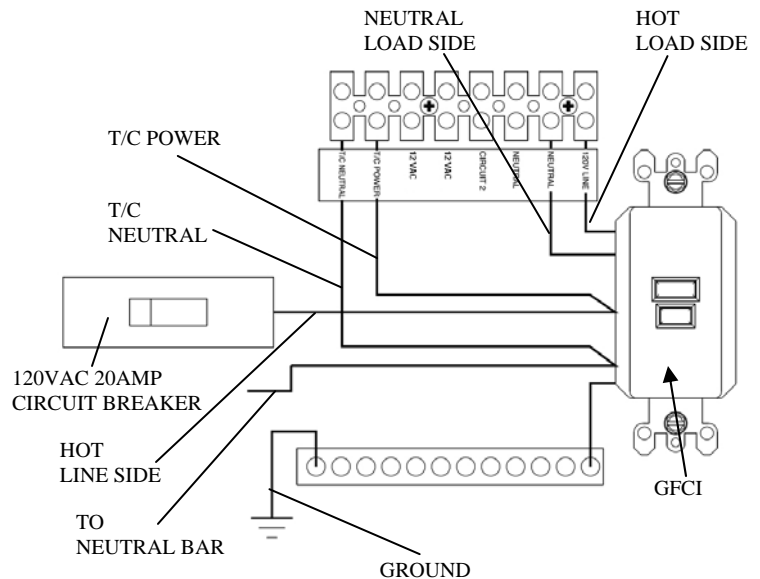

### Hooking up Lights to Circuit 1 and Circuit 2

To connect a lighting product to the Circuit 1 (12 VAC) and Circuit 2 (120 VAC) switch, pull wires from the products to the WPC-2 through conduits connected to the bottom of the WPC-2. As illustrated, connect lights that will be operated by the Circuit 1 Switch to the Circuit 1 terminal. Connect the Neutral to the Terminal Block marked Neutral. Connect the Ground to the Equip. GND. bar. Repeat for Circuit 2. Do not exceed 2.5 amps for Circuit 1 or 8 amps for Circuit 2.

**NOTE:** Some models with optional equipment will have Circuit 1 or Circuit 2 or both Circuits pre-wired for other functions.

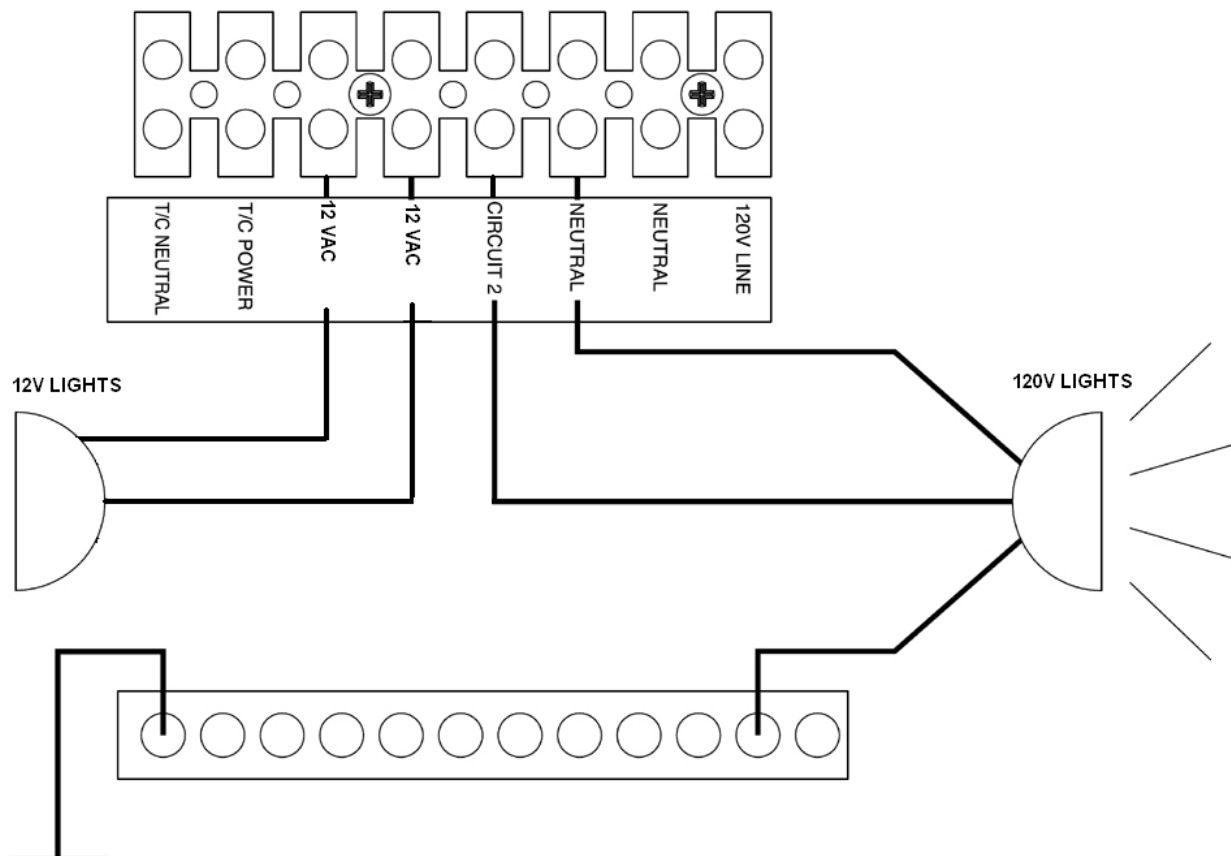

The WPC-3 is approved for use with the Intermatic Metallic Hub Kit (156PA14336A) and Fiberstars DL-HUB for direct connection of underwater lights. Refer to 1999 NEC 680-21(b), 2002 NEC 680-24(b) or CEC 68-060, 062 and 066 for details.

## PUMP CONNECTIONS

**NOTE: Some models are ONLY equipped with Single Speed OR Dual Speed pump connections.**

### CONNECTING A 240VAC PUMP

Connect a 240V 30AMP Circuit Breaker for each pump (if this control box is equipped with optional pump relays). Using an appropriately sized **copper** wires connect to the outer contacts of the JQX relays of the appropriate pumps as shown. Run wires from the pump to the inner contacts of the appropriate JQX relay.

**NOTE:** This unit maybe equipped with more then one JQX relay for pump control.

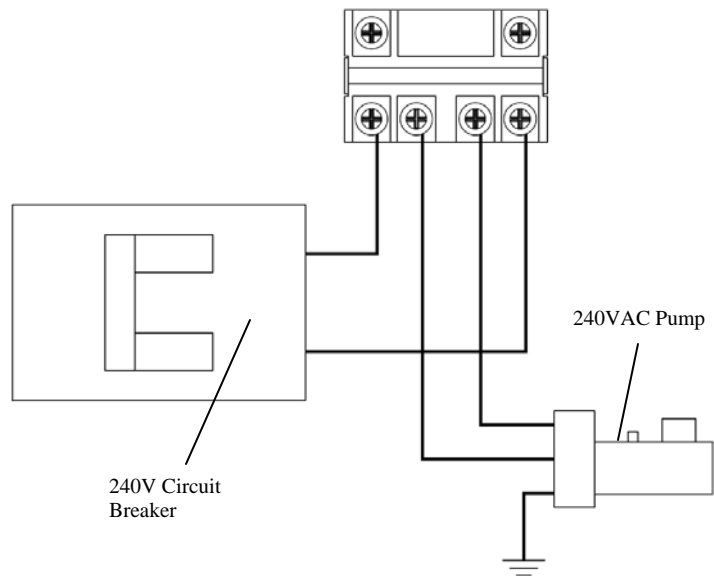

### CONNECTING A 240VAC DUAL SPEED PUMP

As illustrated, connect the Low Speed wire to the Low Speed Load terminal on the terminal block. Connect the High Speed wire to the High Speed Load terminal on the terminal block. Connect the 120V Primary from the 240V Circuit Breaker to the 120V PRI INPUT terminal. Directly connect the 120V Secondary from the Circuit Breaker to the 2 Speed Pump.

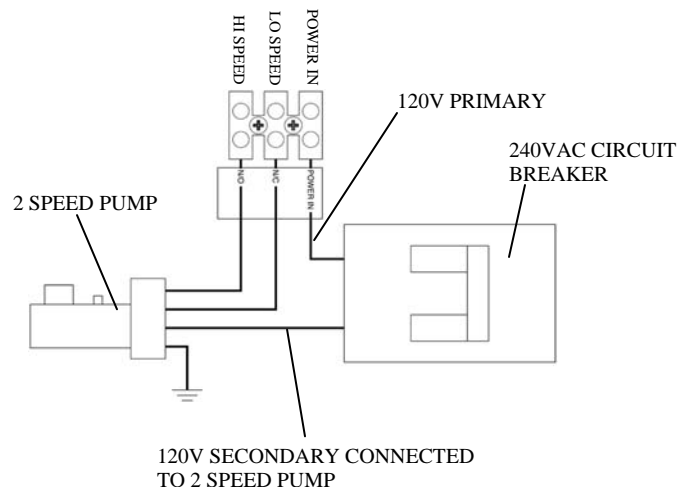

**NOTE: The Secondary 120V must be directly connected to the pump for 240V operation.**

**NOTE: Pump Breaker MUST be turned OFF before servicing as 2<sup>nd</sup> leg of 240V circuit is HOT at all time!**

**24V Valve Wiring (Optional Equipment).**

To connect a 24V Valve, follow diagram as shown. Connect one leg of the 24V common to the 24V TO VALVE terminal. Connect the Close wire to the NC LOAD terminal and the Open wire to the NO LOAD terminal.

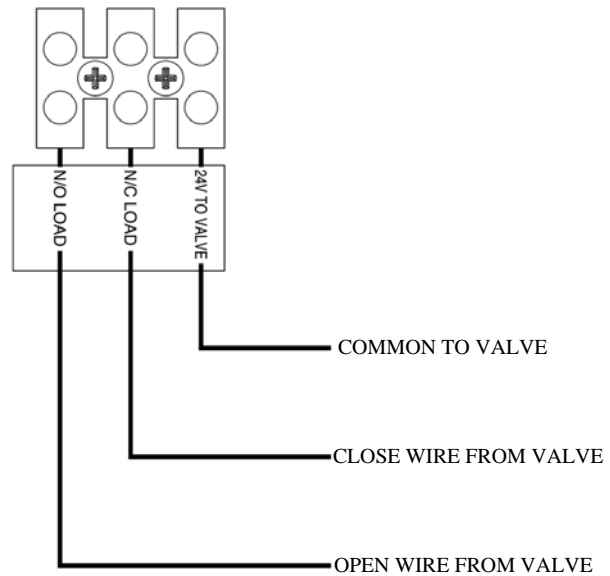

**Heater Connection (Optional Equipment).**

To connect a heater, run the pilot wires from the heater to the WPC unit. Connect the wires to the terminal block labeled Heater.

**NOTE: The Heater circuit only completes the circuit of the Heater terminals when the 24V Valve control is energized to the NO Load circuit.**

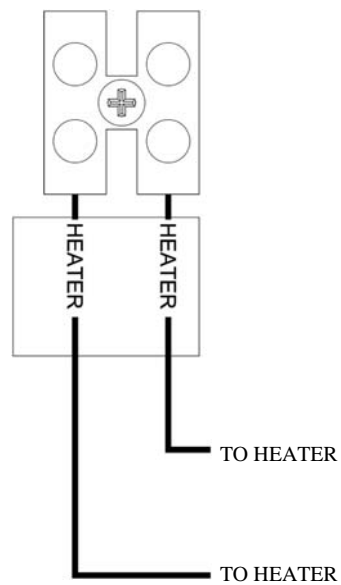



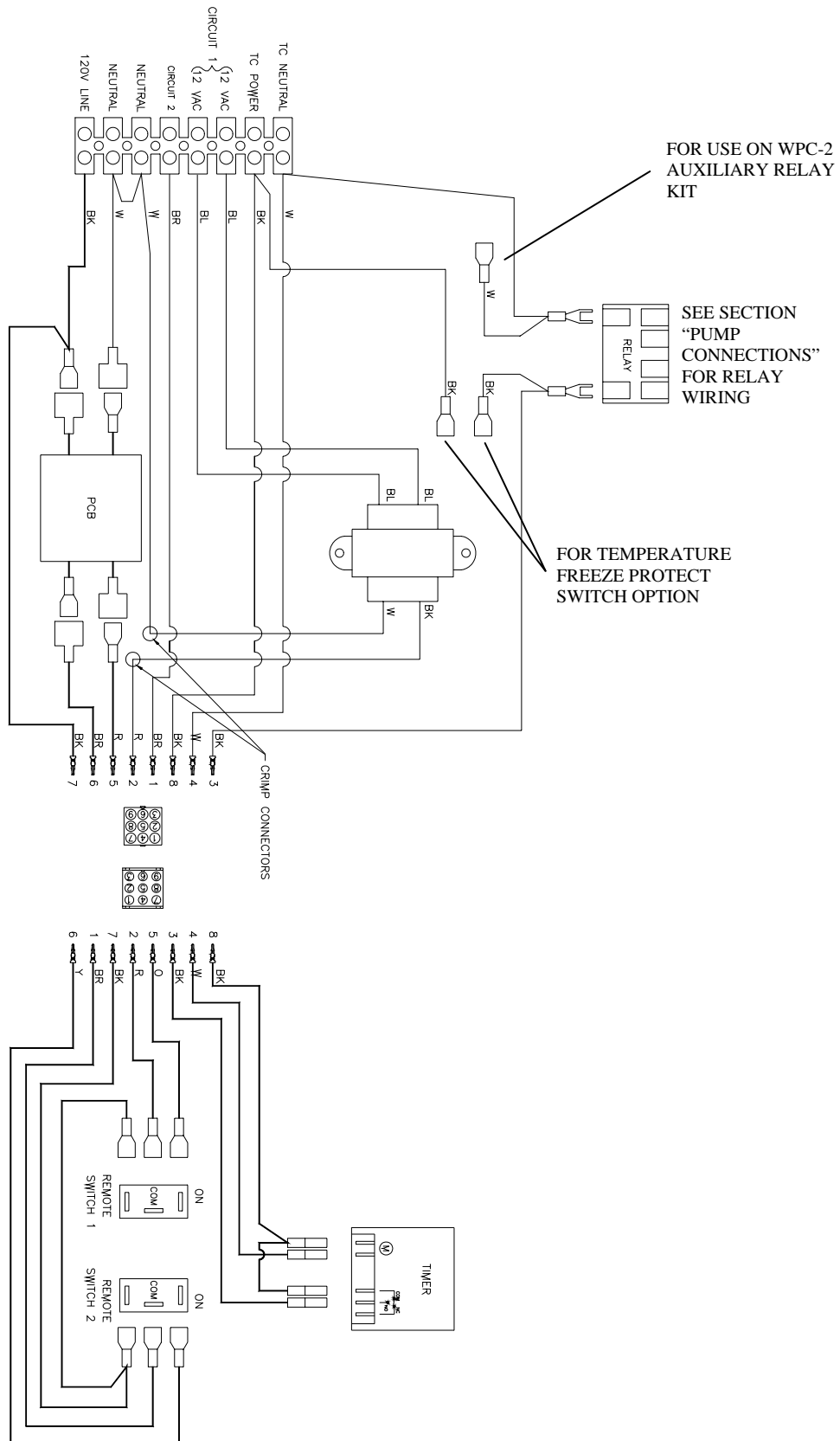

## Repeater Mounting

The WPC-2 is equipped with a signal repeater that can be mounted up to 10 feet from the WPC-2 unit. This repeater receives signals from the wireless remote and sends them to the WPC-2 via a 10 foot cable. Establish a location for the Repeater that is in line of sight from where the wireless remote will be used most frequently and that is no more than 75 feet from where the remote will be used. NOTE: If extension is needed, use Fiberstars part number WE-65 and follow installation instructions supplied with the Repeater Extension.

To mount the Repeater, carefully insert a small flathead screwdriver into groove between the Dome and Base approximately where the locking dimples are located. Pry the Dome out of the locking dimples. Then carefully insert the small flathead screwdriver into the groove between the Dome and the Base in an adjacent locking dimple and pry the Dome out. Then separate the Dome from the Base by hand. Using the supplied self-drilling screws, locate a suitable mounting surface and screw the base to this surface. Note that the marking “TOP” must be in the 12 o’clock position and the wire slit must be in the 6 o’clock position. Do not over tighten the screws as it may damage the Repeater base. Realign the Repeater Dome to the Base and ensure that the wire is exiting the base through the slit and the Locking Dimples are aligned with the locking holes. Apply enough pressure so that the Dome “snaps” into the base.

NOTE: Do not stuff the remainder of the Repeater wire into the WPC unit.

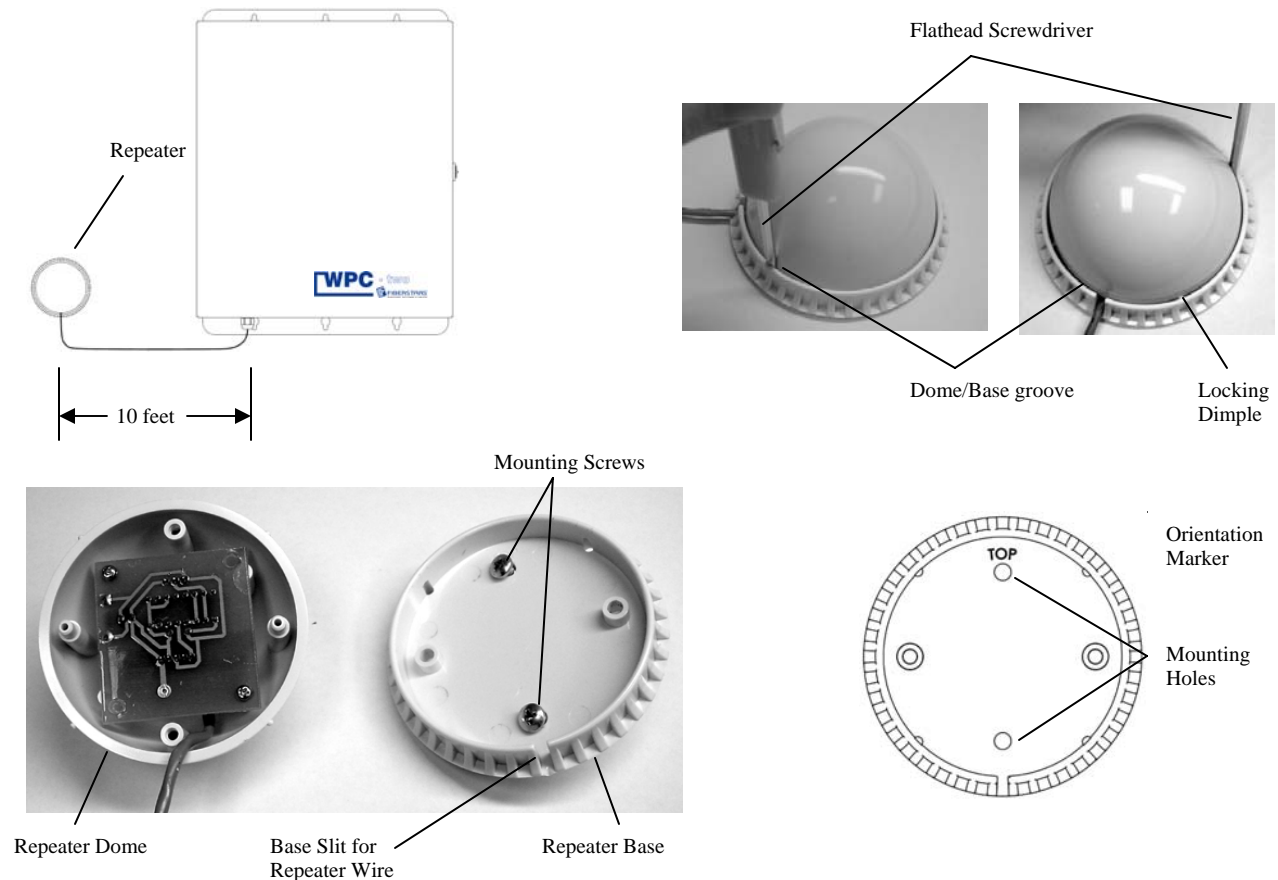

# OPERATING INSTRUCTIONS

## WPC-2 TOGGLE SWITCH OPERATION

The WPC-1 receiver box houses two toggle switches. For operation with the wireless transmitter, the toggle switches need to be in the REMOTE position. To manually turn ON a device connected to Circuit 1 (12 VAC) or Circuit 2 (120 VAC), flip the switch to the ON position. To manually turn OFF a device, flip the switch to the MIDDLE or OFF position. NOTE: If a toggle switch is in the OFF position, wireless remote operation of the device will be disabled. To re-enable wireless remote operation, flip the toggle switch back to the REMOTE position. NOTE: If a device turns ON when the toggle switch is set to the REMOTE position, turn the the wireless remote button OFF to turn off the device.

## Units equipped with toggle switches



**NOTE: Circuit 1 is in the ON position and Circuit 2 is in the REMOTE position**

## WIRELESS REMOTE OPERATION

The toggle switches on the WPC-2 must be set to REMOTE for wireless operation. The POWER ON/OFF buttons control each circuit independently. With each push of the button, the WPC-2 toggles from ON to OFF or OFF to ON. For Synchronized operation, both WPC-1 toggle switches must be set on REMOTE before pushing the SYNC ON/OFF button.

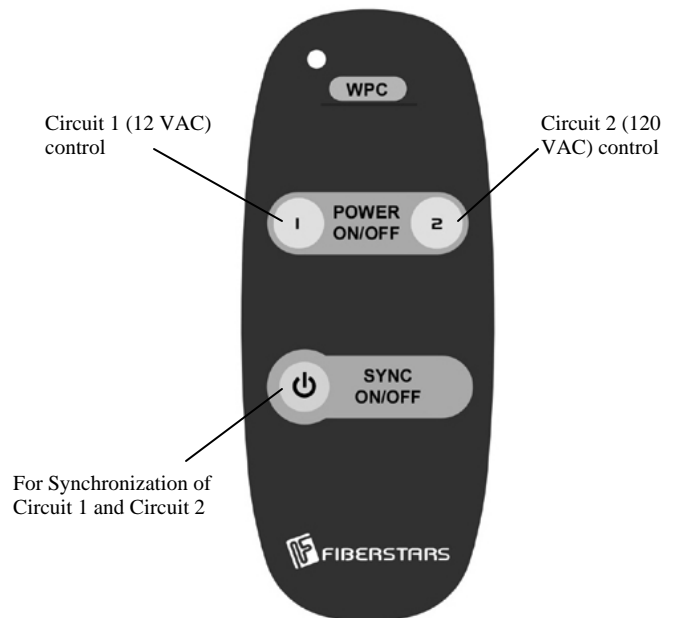

**TIMER OPERATION**

Set time to current time. Open timer cover by lifting from the bottom towards you. In the example below, the current time is set for 9:00 pm. **NOTE: Only turn the Timer dial clockwise or the timer will be damaged.** Once the time has been set to the current time, set the hours of the Pump operation by “snapping” the timer tabs inwards towards the center. **NOTE: Each tab represents 15 minutes of operation and tabs set inwards towards the center is for OFF operations and ON when the tabs are set outwards as illustrated.** In the example below, the Pump will be off from 12:00 pm to 11:45 pm.

Once the time and time of operation has been set, ensure that the Timer function switch is set to Auto for timer control of the Pump as illustrated below. To turn off timers automatic functions, set the Timer function switch to OFF. To manually turn on the Pump, set the Timer function switch to the ON position. **NOTE: When in the ON position, the Pump will continue to run until the Timer function switch is set to Auto where the tabs at the Set Point is in the OFF position or if the Timer function switch is rotated to the OFF position.** Apply the timer label to the timer cover plate. Close the timer cover firmly after timer is set.

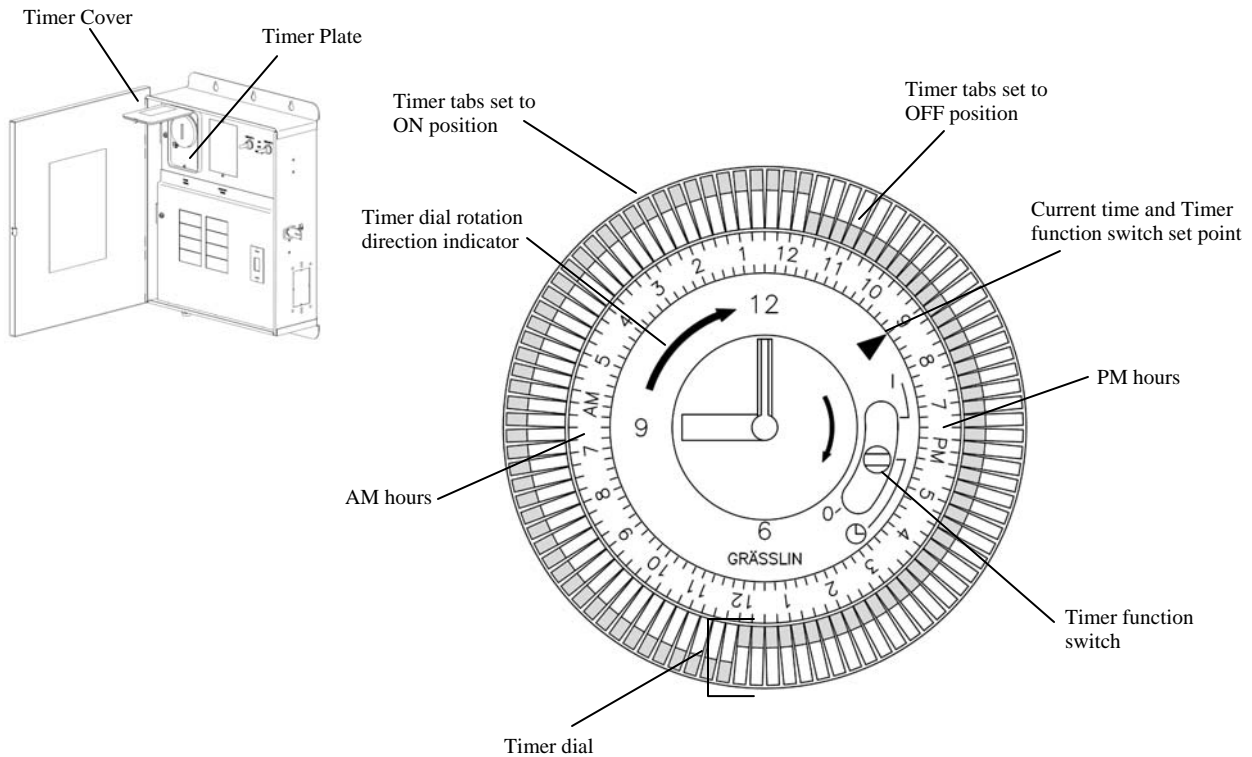

Timer Function Switch Position

- |          |        |
|----------|--------|
| I - ON   | UP     |
| Ⓞ - AUTO | MIDDLE |
| 0 - OFF  | DOWN   |

# CODE ADJUSTMENTS

If it is necessary to change the transmission code on the WPC-2 an adjustment to the receiver AND the transmitter DIP switches must be performed.

**RECEIVER DIP SWITCHES** – Turn OFF power to the WPC-2 from the circuit breaker on the Load Center or from Main Power. Open the enclosure door. Unscrew and remove the Load Center Cover Plate. Place the Cover Bracket in a safe location. Unscrew and remove the Switch Bracket. Disconnect the Molex connector that connects the Switch Bracket controls to the receiver unit and set the Switch Bracket in a safe location where it will not be bent, scratched, or impact forces applied to the components or the face plate itself. Unscrew the four (4) screws holding the receiver to the base of the WPC-2 control box. Unscrew the four (4) screws located on the back of the receiver to release the cover. **NOTE:** Take notice of how the wires enter and exit the receiver. Remove the cover and look on the PCB to locate the DIP switch as illustrated.

**TRANSMITTER DIP SWITCHES** – Remove all screws from rear of remote. Separate the bottom cover from the top cover.

**DIP SWITCH ADJUSTMENT** – The four DIP switches have an ON and an OFF position. Changing just one DIP switch will change the code. **MAKE SURE BOTH THE RECEIVER AND TRANSMITTER HAVE THE SAME DIP SWITCH SETTINGS.**

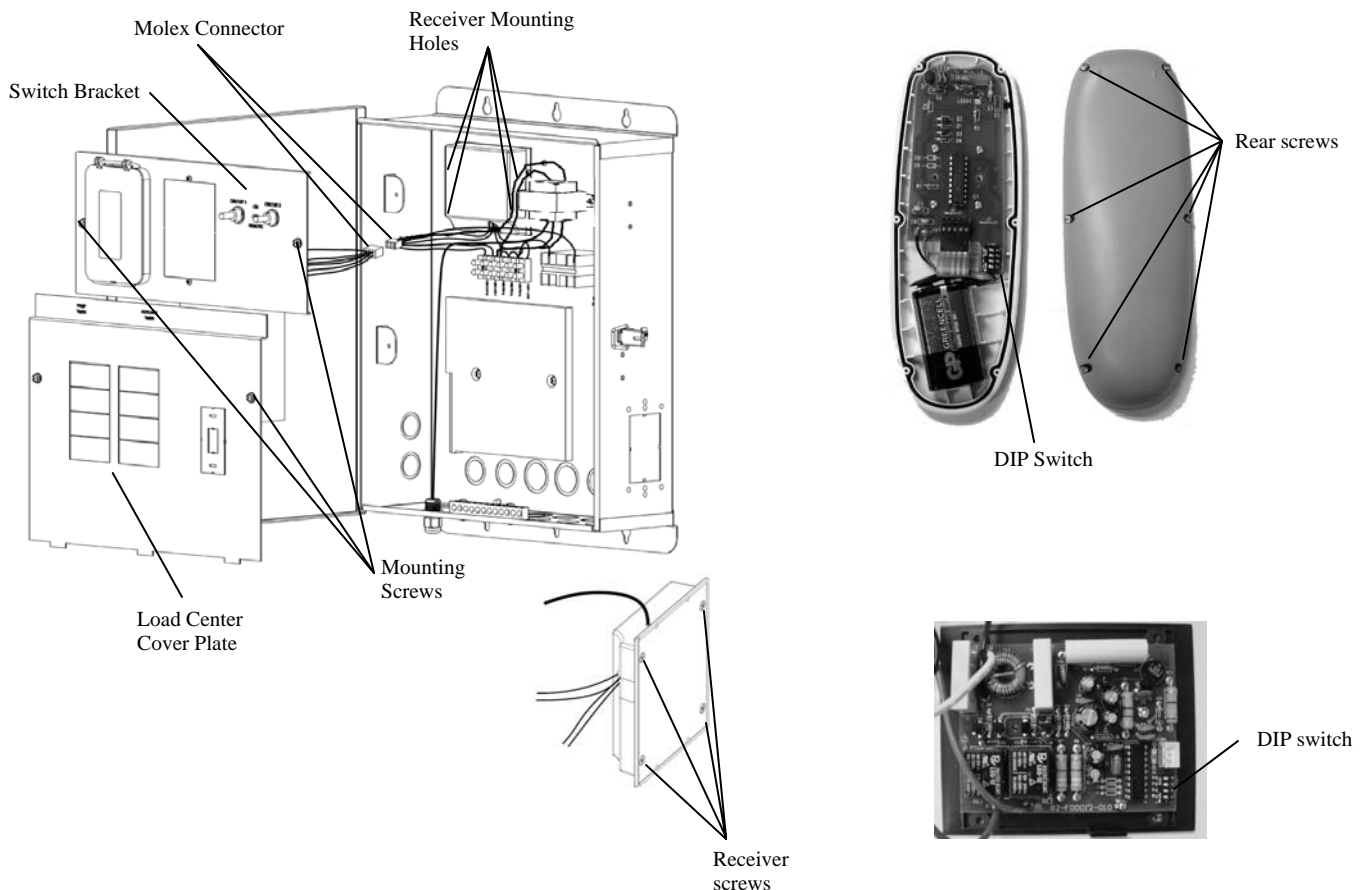

**Note: Sample shown is of Channel 9**

DIP SWITCH	1	2	3	4
Channel 1	OFF	OFF	OFF	OFF
Channel 2	ON	OFF	OFF	OFF
Channel 3	OFF	ON	OFF	OFF
Channel 4	ON	ON	OFF	OFF
Channel 5	OFF	OFF	ON	OFF
Channel 6	ON	OFF	ON	OFF
Channel 7	OFF	ON	ON	OFF
Channel 8	ON	ON	ON	OFF
Channel 9	OFF	OFF	OFF	ON
Channel 10	ON	OFF	OFF	ON
Channel 11	OFF	ON	OFF	ON
Channel 12	ON	ON	OFF	ON
Channel 13	OFF	OFF	ON	ON
Channel 14	ON	OFF	ON	ON
Channel 15	OFF	ON	ON	ON
Channel 16	ON	ON	ON	ON

CHANNEL

1	5	9	13
2	6	10	14
3	7	11	15
4	8	12	16



DIP Switch

## WPC FUNCTION CHART

Below is a chart of the WPC functionality based on the model number.

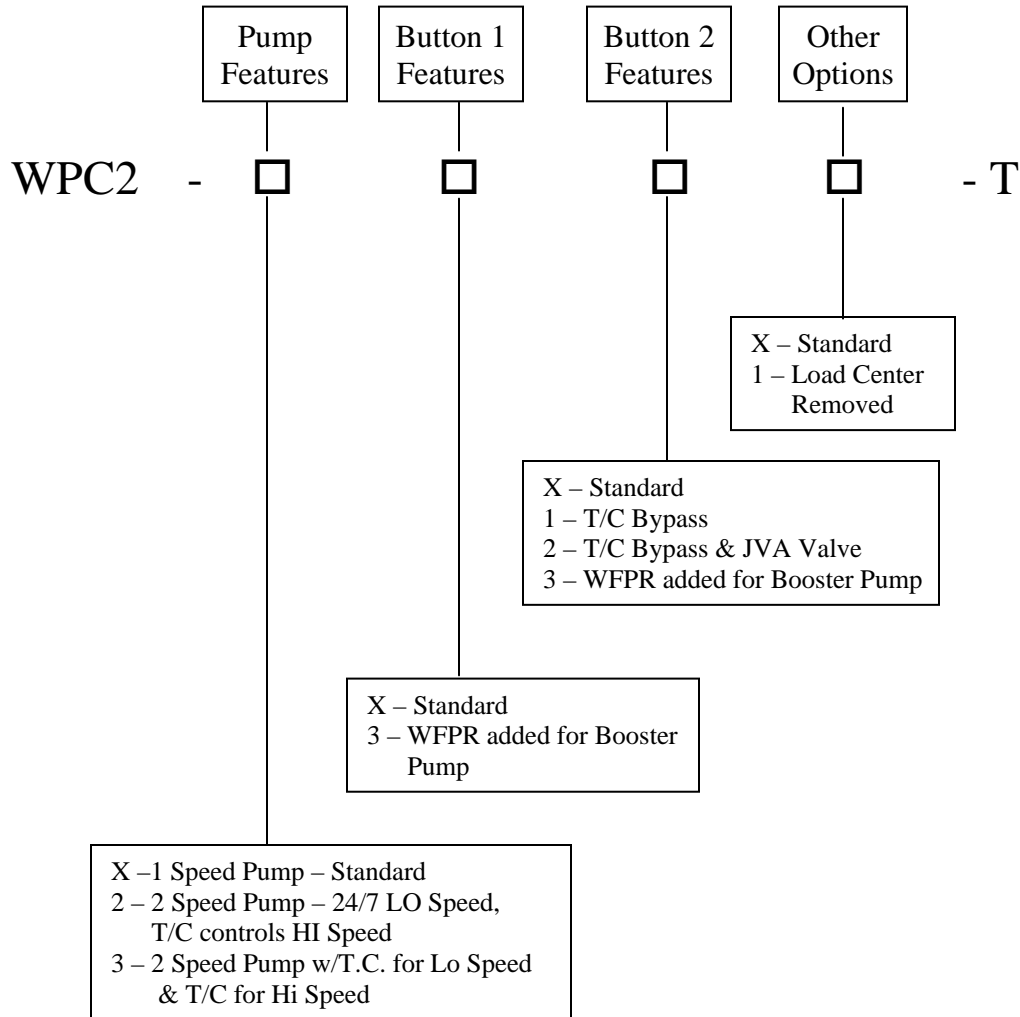

### EXAMPLE:

WPC2-2X2X-T is a 2 speed pump model with the Low Speed ON continuously until High Speed is actuated by the Time Clock. Button 1/Circuit 1 is wired standard. Button 2/Circuit 2 is wired as a Time Clock Bypass & JVA which actuates a JVA valve and turns on the High Speed pump (if Time Clock is already ON, then this action will keep the High Speed ON even after the Time Clock has Shut OFF) with the push of the Button 2 on the remote or flipping the Circuit 2 switch to ON.